

Instructions For Following Product(s)

- All standard Highline Credenzas

Product(s) Required But Ordered Separately

- None

Related Instructions

- 02D00018 - Cabinet Door Hinge
- 02D00019 - Cabinet Drawer Slide
- 02D00020 - Cabinet Trash Drawer

Tools Required



Driver\Drill Gun



Tape Measure



Driver Bit,
Phillips #2



Open-End Wrench,
7/16"



Internal Hex Driver,
3/16"

In The Box (Supplied By DatesWeiser)

(A) CREDENZA CASES AVAILABLE IN 3 STANDARD HEIGHTS

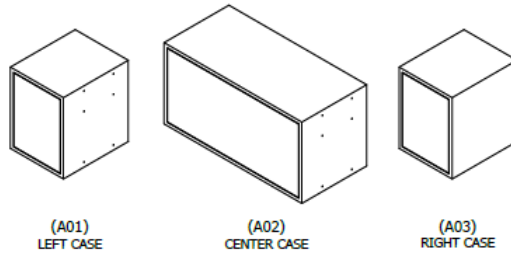

(A01)
LEFT CASE

(A02)
CENTER CASE

(A03)
RIGHT CASE

(B) CREDENZA LEG & CASE MOUNT

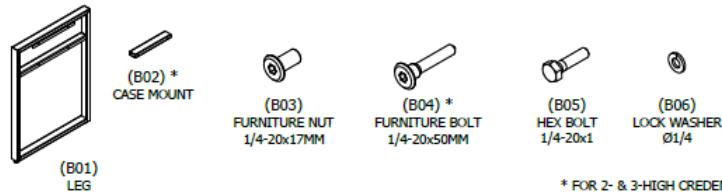

(B01)
LEG

(B02) *
CASE MOUNT

(B03)
FURNITURE NUT
1/4-20x17MM

(B04) *
FURNITURE BOLT
1/4-20x50MM

(B05)
HEX BOLT
1/4-20x1

(B06)
LOCK WASHER
Ø1/4

* FOR 2- & 3-HIGH CREDENZA

(C) ACCENT TOPS

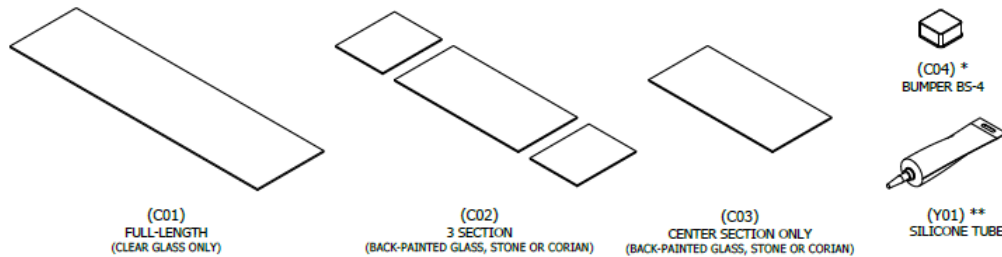

(C01)
FULL-LENGTH
(CLEAR GLASS ONLY)

(C02)
3 SECTION
(BACK-PAINTED GLASS, STONE OR CORIAN)

(C03)
CENTER SECTION ONLY
(BACK-PAINTED GLASS, STONE OR CORIAN)

(C04) *
BUMPER BS-4

(Y01) **
SILICONE TUBE

* FOR FULL-LENGTH CLEAR GLASS
** FOR SECTIONED BACK-PAINTED GLASS, STONE OR CORIAN

(D) TRASH LINER

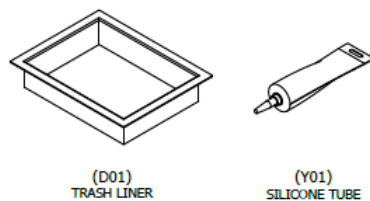

(D01)
TRASH LINER

(Y01)
SILICONE TUBE

(E) PULLS

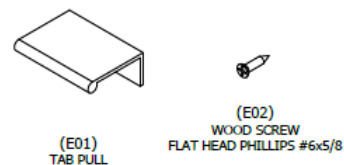

(E01)
TAB PULL

(E02)
WOOD SCREW
FLAT HEAD PHILLIPS #6x5/8

Door & Drawer Removal

Note:

For ease of assembly, it's strongly recommended to remove any Doors or Drawers before you begin assembly.

- For details on Door removal, see instruction 02D00018.
- For details on Drawer removal, see instruction 02D00019.
- For details on Trash removal, see instruction 02D00020.

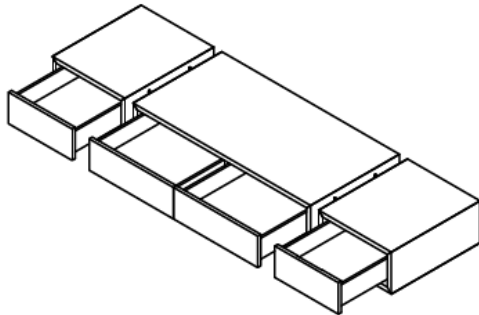

1-HIGH CREDENZA w\ DRAWERS

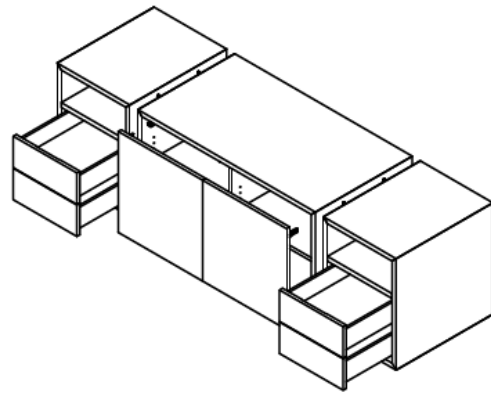

3-HIGH CREDENZA w\ DOORS & DRAWERS

FIG 01:
DOOR & DRAWER REMOVAL

Case & Leg Assembly

Center Case & Leg

1. Prepare Legs (B01) for assembly to Center Case by installing Hex Bolt (B05) with Lock Washer (B06) into threaded holes one side of each Leg. See Figure 02.
2. Stand Center Case (A02) on end. Then using Hex Bolts previously assembled to Legs, locate and secure one Leg to the Case using Furniture Nut (B03). See Figure 03.
3. If assembling a 2- or 3-High Credenza, use Furniture Bolt (B04) to attach Case Mount (B02). See Figure 04.
4. Flip sub-assembly to stand on assembled Leg and repeat the steps 2-3 to attach the other Leg. See Figure 05.

End Case & Leg

1. Stand Center Case assembly up right and position as close as possible to its final position. See Figure 06.
2. Prepare Legs (B01) for assembly to End Cases (A01\A03), installing Hex Bolt (B05) with Lock Washer (B06) into threaded holes on other side of each Leg. See Figure 07.
3. Using the Hex Bolts previously assembled to the Legs, locate and secure the End Cases using Furniture Nut (B03). See Figure 08.
4. If assembling a 2- or 3-High Credenza, use Furniture Bolt (B04) to attach Case Mount (B02). See Figure 08.
5. If assembling a 1-High Credenza, verify the squareness of the Cases and Legs. If adjustments are needed, loosen\tighten the set screws located inside the Cases (On End Panels near the Bottom Panel). See Figure 09.

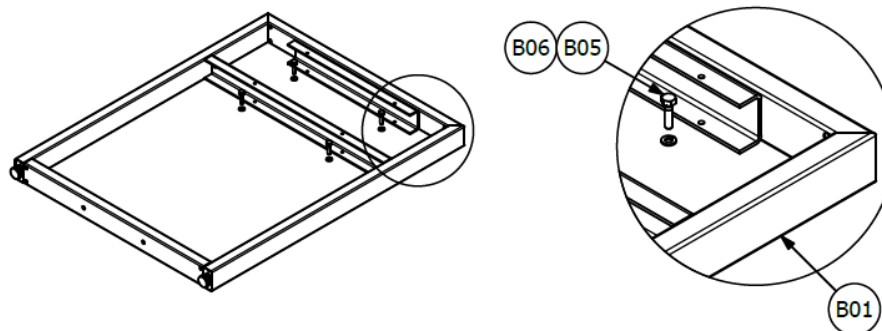
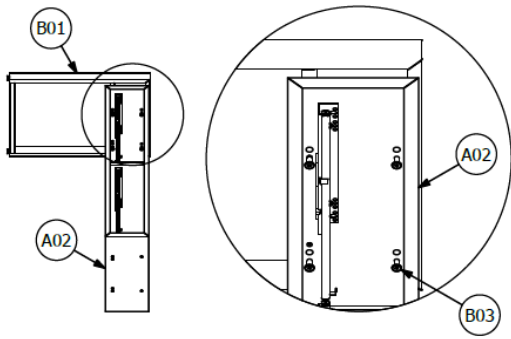
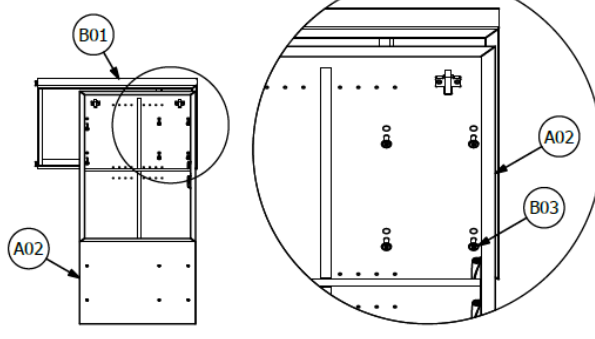

FIG 02:
LEG PREP FOR ATTACHMENT TO CENTER CASE

Case & Leg Assembly



1-HIGH CENTER CASE



3-HIGH CENTER CASE

FIG 03:
CENTER CASE & LEG ASSEMBLY

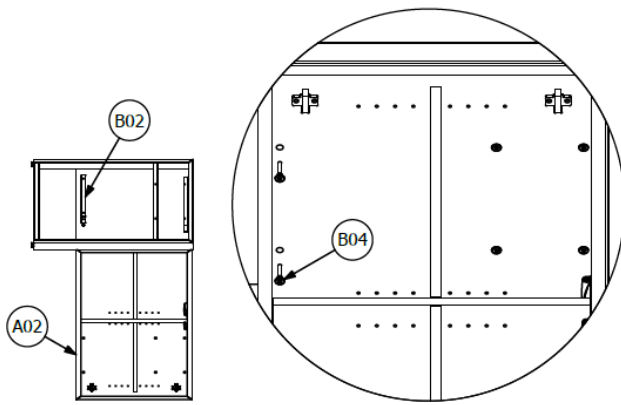

CASE MOUNT ON
OUTSIDE OF CENTER CASE

FURNITURE BOLTS ON
INSIDE OF CENTER CASE

FIG. 04:
CASE MOUNT ASSEMBLY

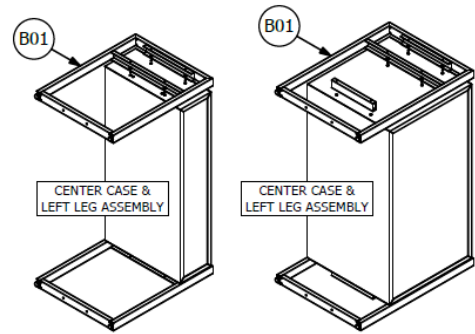

1-HIGH CENTER CASE

3-HIGH CENTER CASE

FIG. 05:
CENTER CASE & RIGHT LEG ASSEMBLY

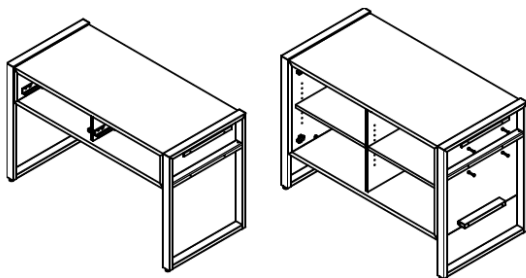

1-HIGH CENTER CASE

3-HIGH CENTER CASE

FIG 06:
CENTER CASE & LEG ASSEMBLY STANDING UP-RIGHT

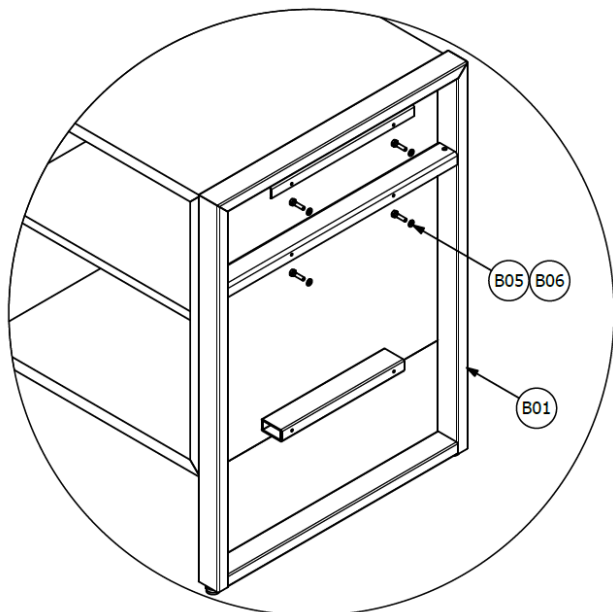

FIG 07:
LEG PREP FOR ATTACHMENT TO END CASES
(3-HIGH CASE SHOWN)

Case & Leg Assembly

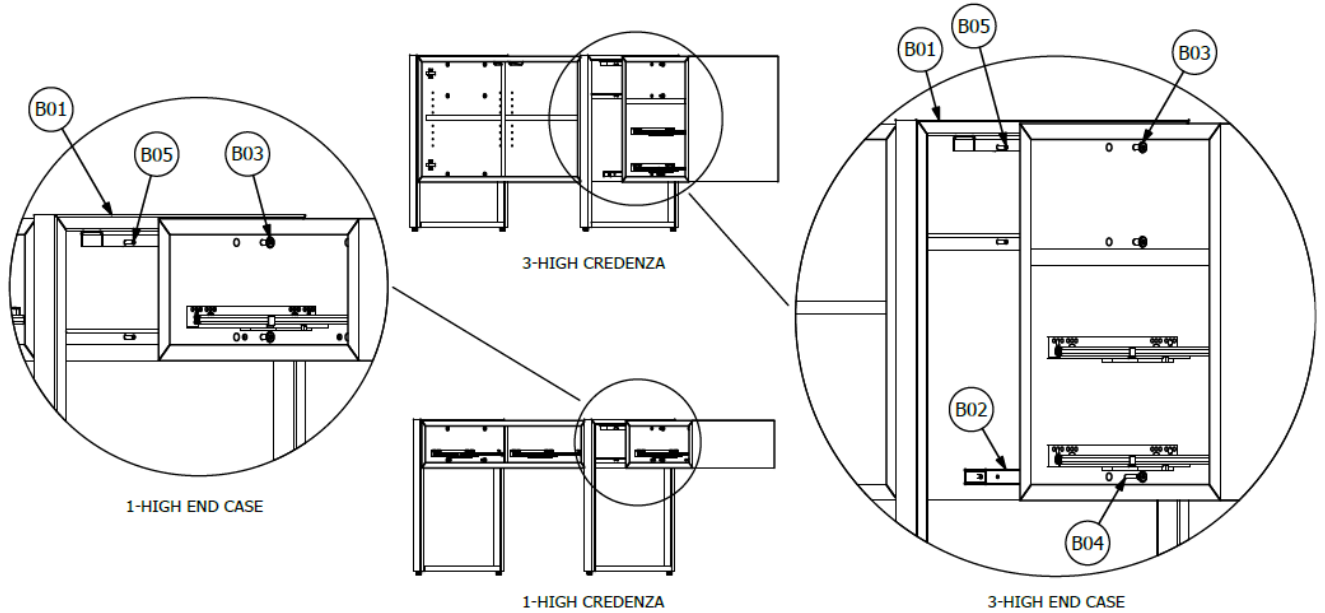

FIG. 08:
END CASE & LEG ASSEMBLY

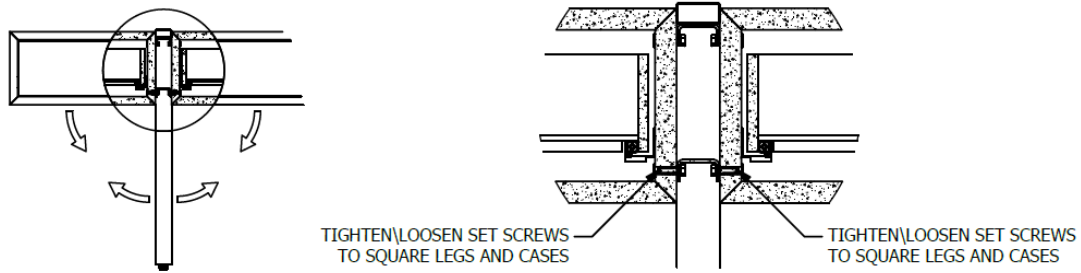

FIGURE 09:
1-HIGH CREDENZA SQUARENESS ADJUSTMENTS

Door & Drawer Re-Assembly

- For details on Door removal, see instruction 02D00018.
- For details on Drawer removal, see instruction 02D00019.
- For details on Trash removal, see instruction 02D00020.

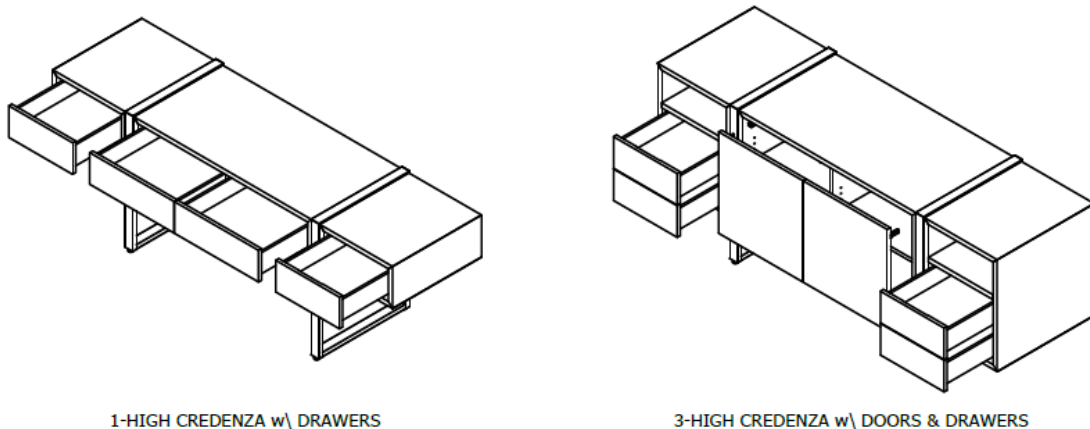

FIG. 10:
DOOR & DRAWER RE-ASSEMBLY

Pull Assembly (If Equipped)

Note:

Skip forward to "Trash Liner Assembly" if Credenza is not equipped with Pulls.

1. Using Wood Screw E02, attach Pulls (E01) to Drawer Fronts. See Figure 11.

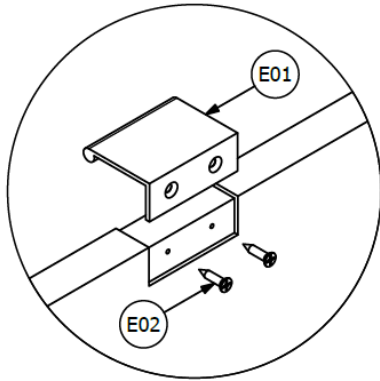

FIG. 11:
TAB PULL ASSEMBLY

Trash Liner Assembly (If Equipped)

Note:

Skip forward to "Position & Level" if Credenza is not equipped with Trash Liners.

1. Using small dabs of Silicone (Y01), secure Trash Liner (D01) into Trash Liner cutout(s). See Figure 12.

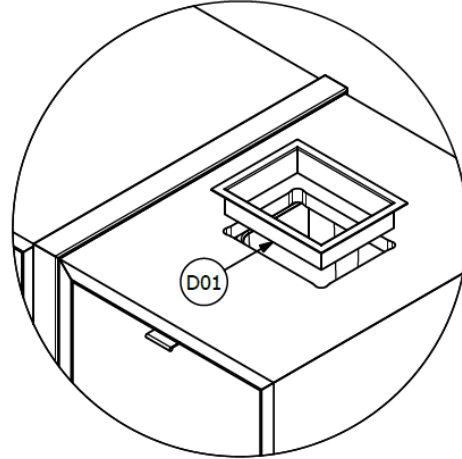

FIG. 12:
TRASH LINER ASSEMBLY

Position & Level

1. With Credenza is in its final position, use a level to adjust the leg levelers and level the Credenza. See Figure 13.

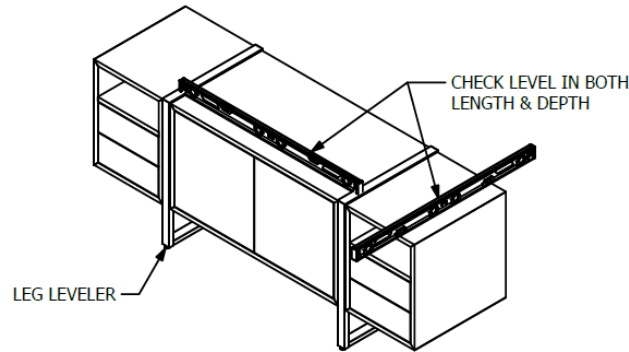

FIG. 13:
POSITION & LEVEL

Top Assembly

Note:

Assembly is complete if Credenza is not equipped with an Accent Top.

Full Length (Clear Glass Only)

1. Peel and stick Bumpers (C04), placing one in each corner of the credenza inset approximately 1" to the center of the Bumper. Then (Spaced equally) stick the remaining Bumpers along the length of the Credenza. See Figure 14.
2. Place Clear Glass Top (C01) on Bumpers, flush at ends and flush to Legs. See Figure 14.

3 Section (Back-Painted Glass, Stone or Corian)

1. Using small dabs of Silicone (Y01) around the perimeter, secure all Top Sections (C02) centered on each Case and inset 1" on all sides. See Figure 15.

Center Section (Back-Painted Glass, Stone or Corian)

1. Using small dabs of Silicone (Y01) around the perimeter, secure Center Top Section (C03) centered on Center Case and inset 1" on all sides. See Figure 15.

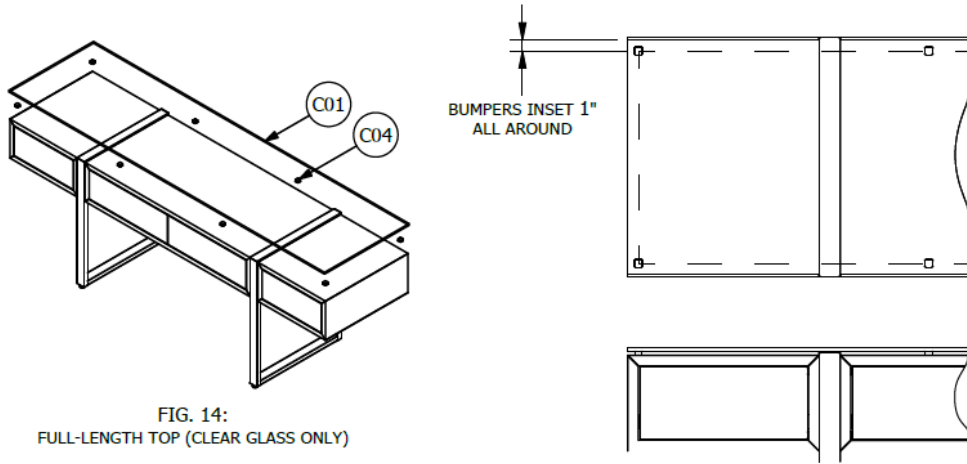

FIG. 14:
FULL-LENGTH TOP (CLEAR GLASS ONLY)

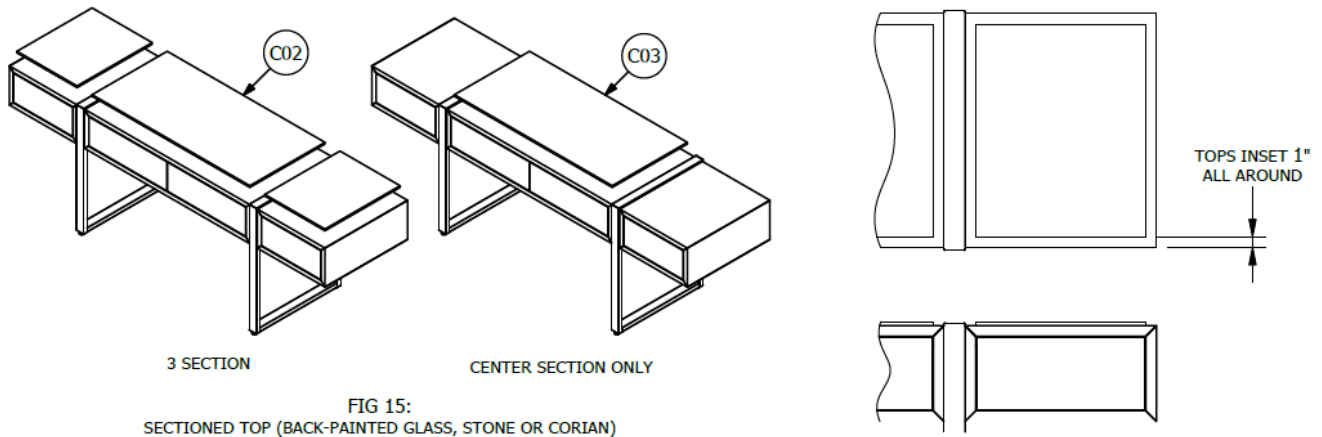

FIG 15:
SECTIONED TOP (BACK-PAINTED GLASS, STONE OR CORIAN)