

Instructions For Following Product(s)

- All Highline Square, Round & Elliptical Meeting Tables w\ Wood X-Bases

Product(s) Required But Ordered Separately

- None

Related Instructions

- 00D00012 Unify Power System Components
- 00D00015 Unify Double-Sided Meeting Tabletop Power
- 00D00016 Unify Undermount Power
- 00D00017 Unify Edgemount Power

Tools Required



Pencil, Pen or Marker



Tape Measure



Level



Driver\Drill Gun



Phillips Driver #2



Phillips Driver #3

In The Box (Supplied By DatesWeiser) - Bases

(A) XOT-BASE (FOR ROUND & SQUARE TABLES w\ METAL TRIM)

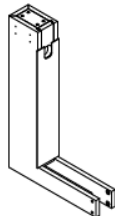

(A01)
LONG LEG

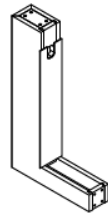

(A02)
SHORT LEG



(A03)
BOTTOM ACCESS PANEL



(Y01)
FURNITURE BOLT
1/4-20x50MM



(Y02)
MACHINE SCREW
PAN HEAD PHILLIPS 5/16-18x2
ZINC

(B) XOT-BASE (FOR ROUND & SQUARE TABLES w\ WOOD TRIM)

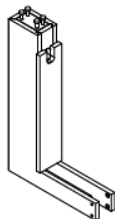

(B01)
LONG LEG

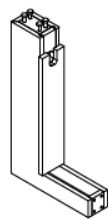

(B02)
SHORT LEG



(B03)
BOTTOM ACCESS PANEL



(Y01)
FURNITURE BOLT
1/4-20x50MM



(Y02)
MACHINE SCREW
PAN HEAD PHILLIPS 5/16-18x2
ZINC

(C) SUPPORT ARMS (IF EQUIPPED)

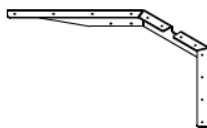

(C01)
STEEL SUPPORT ARMS



(Y03)
WOOD SCREW
PAN HEAD PHILLIPS #12x1
BLACK

In The Box (Supplied By DatesWeiser) – Tabletop

(D) TABLE TOP (SHAPE VARIES)

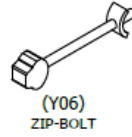
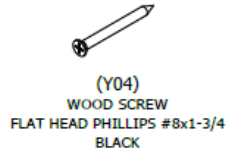
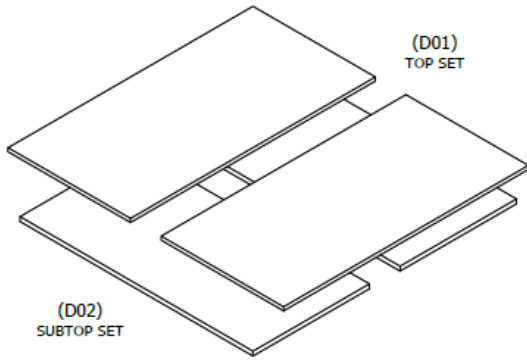

(E) ALTERNATIVE MATERIAL TOP (IF EQUIPPED)

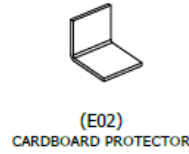
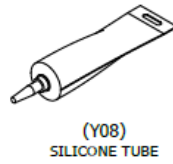
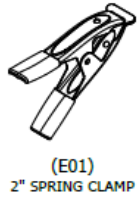

(F) EDGE TRIM (IF EQUIPPED)

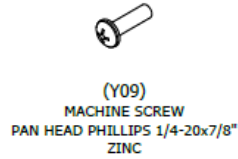
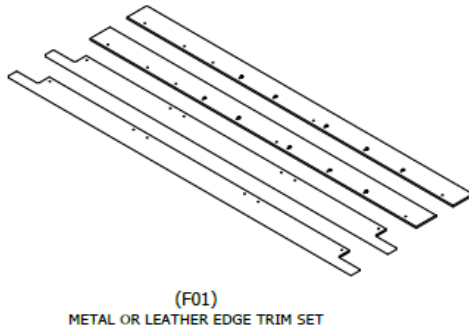

In The Box (Supplied By DatesWeiser) – Power & Connectivity

(G) TOPMOUNT POWER (IF EQUIPPED)

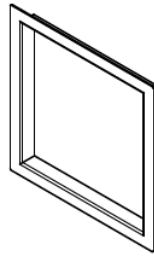

(G01)
TOPMOUNT LINER



(G02)
TOPMOUNT LINER
SPACER

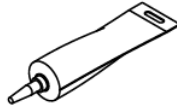

(Y08)
SILICONE TUBE

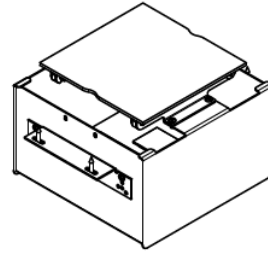

(G03)
DOUBLE-SIDED MEETING
TABLETOP POWER BOX ASSEMBLY

(H) UNDERMOUNT POWER (IF EQUIPPED)

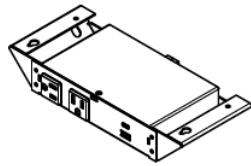

(H01)
UNDERMOUNT POWER BOX
ASSEMBLY

(J) EDMOUNT POWER (IF EQUIPPED)

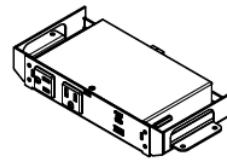

(J01)
EDGMOUNT POWER BOX
ASSEMBLY

Assembly Instructions - Bases

XON- & XOT-Bases (For Round & Square Tables)

1. Using Fastener (Y01), assemble both Long Legs (A01\B01) and Short Legs (A02\B02) to complete base assembly. See Figure 01.
2. If the table is equipped with Power Drawers, Steel Support Arm (C01) will be included. Using Fastener (Y03) attach Support Arms to Bases using the pilot holes provided. See Figure 01.

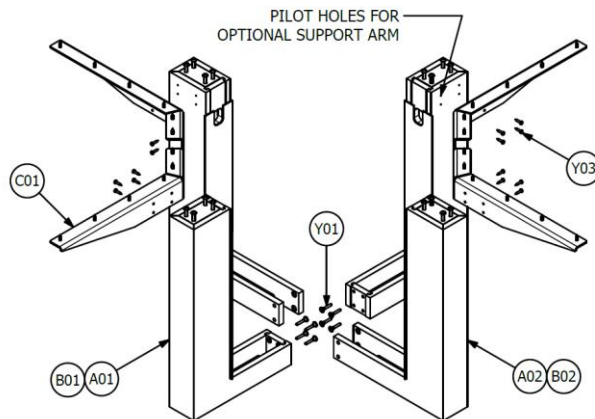

FIGURE 01: X-BASE ASSEMBLY

Assembly Instructions - Topmount Power Box w\ Lid (If Equipped)

Note:

Skip forward to Subtop Assembly Instructions if table is not equipped with Topmount Power.

1. Refer to instructions 02D00016 for installation of Meeting Tabletop Power (G03).

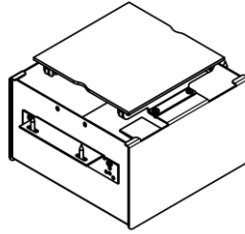

Assembly Instructions - Subtops

1-Piece Subtop

1. Place Subtop (D02) on Table Base with holes to attach Subtop facing down. See Figure 02.
2. Align counter-bored holes in Subtop to threaded inserts in base legs, then use Fastener (Y02) to secure them. See Figure 02.
3. If the table is equipped with Support Arms (C01), use Fastener (Y03) to secure them to the Subtop. See Figure 02.

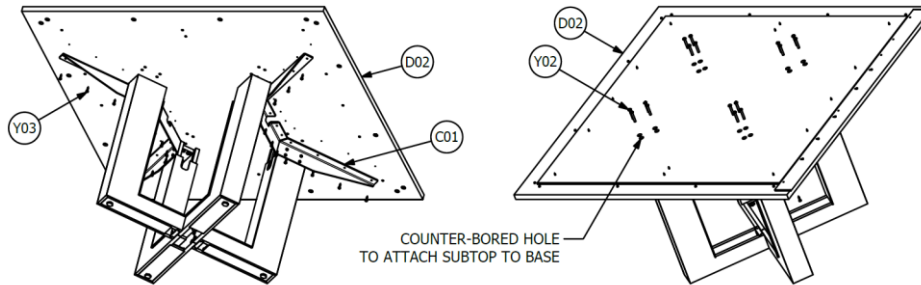

FIGURE 02: 1-PIECE SUBTOP ASSEMBLY

2-Piece Subtop

1. Place **All** Subtop (D02) sections on Table Base with holes to attach Subtop facing down. See Figure 03.
2. Using Biscuit (Y05) and Zip-Bolt (Y06) connect the Subtop sections to each other. See Figure 03.

!!! Do Not Overtighten !!!

To prevent stripping Zip-Bolt Fasteners, tighten by hand using 4mm Allen Key (Y07) included with table.

3. Align counter-bored holes in Subtop to threaded inserts in base legs, then use Fastener (Y02) to secure them. See Figure 03.
4. If the table is equipped with Support Arms (C01), use Fastener (Y03) to secure them to the Subtop. See Figure 03.

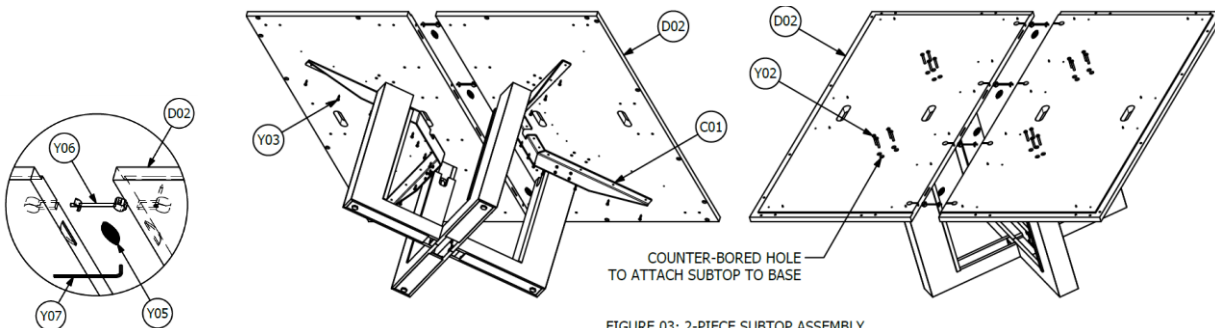

FIGURE 03: 2-PIECE SUBTOP ASSEMBLY

Assembly Instructions – Edge Trim (If Equipped)

Note:

- Skip forward to Subtop Leveling Instructions if table is not equipped with Edge Trims.

Metal Edge Trim (Painted, Plated Or Leather Wrapped)

1. Layout Edge Trims (F01) around Subtop matching the numbers marked on both, making sure the numbers always face up. See Figure 04.
2. Secure Edge Trims to Subtop from underneath using Fastener (Y09) into threaded holes of Edge Trim. See Figure 04.
3. Flush Edge Trims by loosening fasteners and shimming to make any necessary adjustments.

!!! Do Not Overtighten !!!

Screw must not protrude above top surface of Edge Trim.

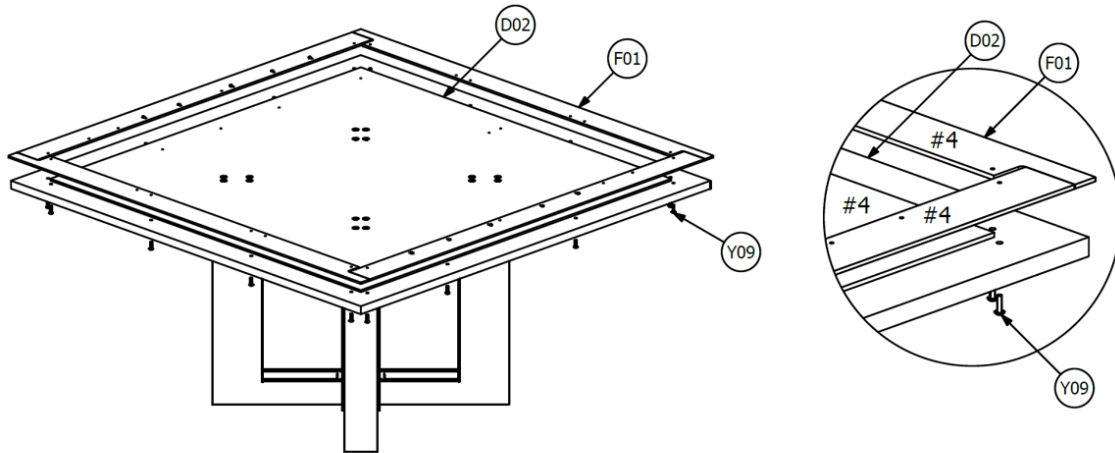

FIGURE 04: EDGE TRIM ASSEMBLY

Leveling Table w\ Subtop Assembled (This Is An Extremely Important Step)

1. Using a Level to measure, adjust the Base Levelers to level the table.

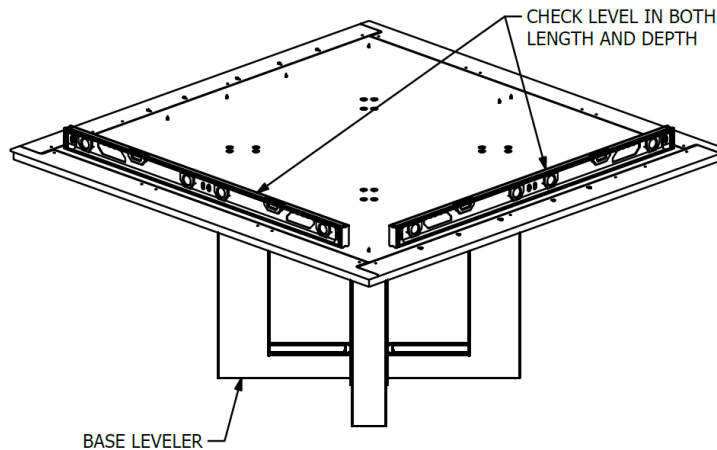

FIGURE 05: SUBTOP LEVELING

Assembly Instructions – Wood Top

Note:

- Skip forward to section for Assembly of Alternative Material Tops if your table is equipped with anything other than a Wood Top.

1-Piece Top

1. Place Top (D01) on Subtop (D02). See Figure 06.
2. If equipped with Edge Trim (F01), position the Top so that an equal amount (1/4") of the Edge Trim shows. If not equipped with an Edge Trim, center Top on Subtop. See Figure 06.
3. Once Top is positioned, use Fastener (Y04) to secure them. See Figure 06.

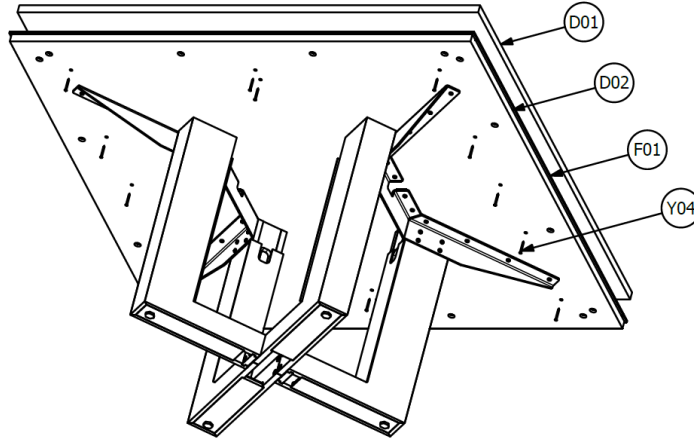

FIGURE 06: 1-PIECE WOOD TOP ASSEMBLY

2-Piece Top

1. Place ALL Top (D01) sections on Subtop (D02). See Figure 07.
2. Using Zip-bolt (Y06) connect the Top sections to each other thru the openings in the Subtop. See Figure 07.

!!! Do Not Overtighten !!!

To prevent stripping Zip-Bolt Fasteners, tighten by hand using 4mm Allen Key (Y07) included with table.

3. If equipped with Edge Trim (F01), position the Top Assembly so that an equal amount (1/4") of Edge Trim shows. If not equipped with Edge Trim, center Top on Subtop. See Figure 07.
4. Once Top is positioned, use Fastener (Y04) to secure them. See Figure 07.

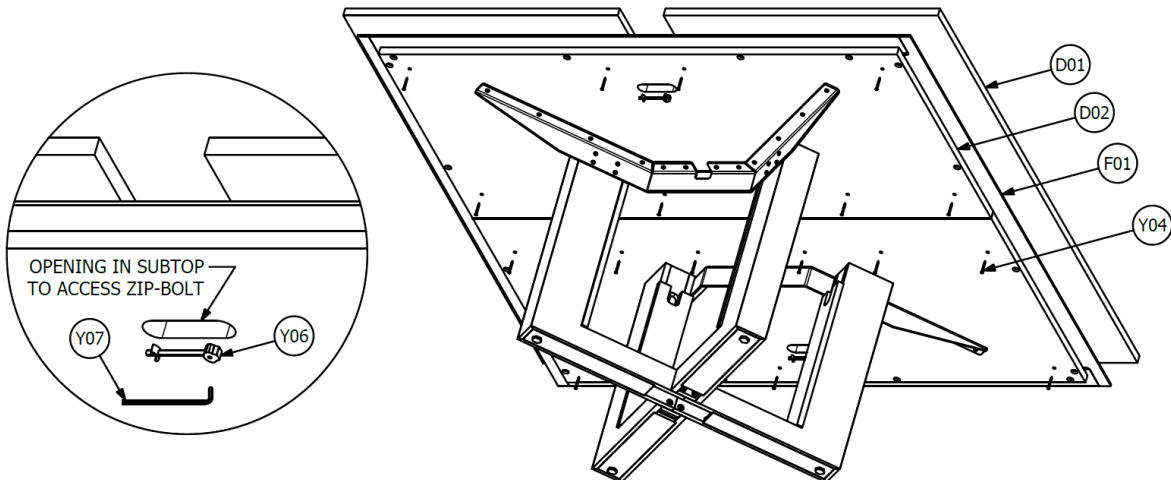

FIGURE 07: 2-PIECE WOOD TOP ASSEMBLY

Assembly Instructions – Alternative Material Top

Before You Begin:

Dry fit All Tops before gluing down to insure proper fit.

1- & 2-Piece Tops

1. Place a 1/2" Dab of Silicone (Y08) provided on marked locations of Subtop (D02) approximately 5" in from the Edge. See Figure 08.
Silicone Specification: Dap 100% Clear Silicone Rubber Sealant, No substitutes (provided By Datesweiser).
2. Position **All** Top (D01) sections on Subtop (D02). See Figure 08.
3. If equipped with Edge Trim (F01), position the Top (Suction cups are recommended) so that an equal amount (1/4") of Edge Trim Shows. If not equipped with an Edge Trim, center the Top on the Subtop. See Figure 08.

Note:

- If top is glass, make sure the painted side is facing down.

4. Using Clamps (E01) supplied with the table, clamp the Top in place while the silicone sets. See section "Clamp Layout Guide" for recommended clamping locations.

Note:

- Silicone must cure a minimum of 24 hours before Clamps can be removed.
- Use supplied Cardboard Protection (E02) for Stone Tops only.
- Clamps not required for Tops with recessed Subtop and No Metal Edge combination.

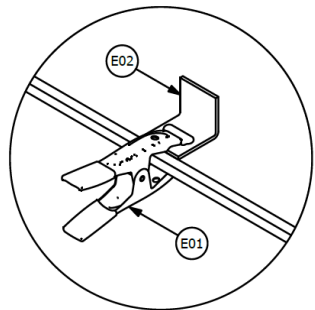

APPLIED CLAMP
(SHOWN w\ CARDBOARD PROTECTOR
FOR GLASS TOP)

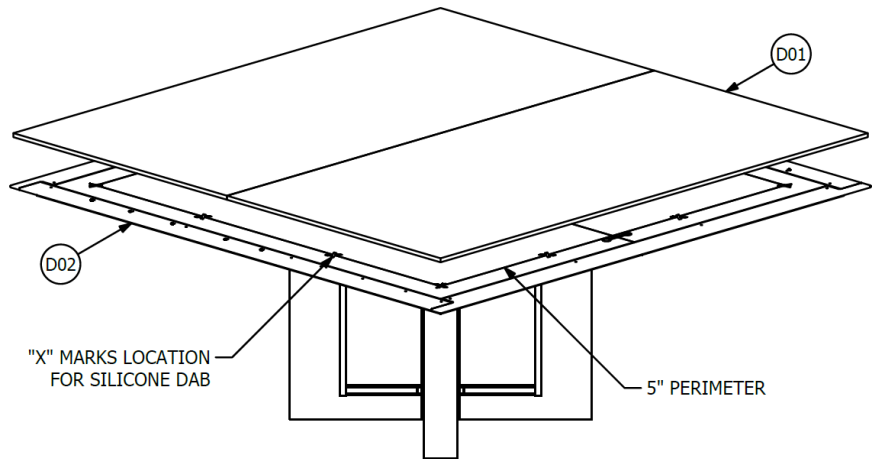

FIGURE 08: ALTERNATIVE MATERIAL TOP ASSEMBLY

Clamp Layout Guide

For Alternative Material Tops (i.e. Solid Surface, Stone, Glass)

Note:

- Silicone must cure a minimum of 24 hours before Clamps can be removed.

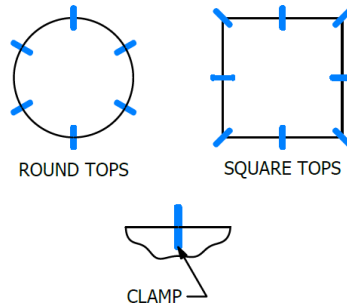

FIGURE 09: CLAMP LAYOUT GUIDE

Assembly Instructions – Topmount Liner (If Equipped)

Note:

- Skip forward to Table Leveling Check Instructions if table is not equipped with Topmount Power.

1. Using small dabs of Silicone (Y08), locate and secure Topmount Liner (G01) using L-Shaped Spacer (G02) in all four corners.
2. Wait 15 minutes for Silicone to partially set, then remove and discard spacers.

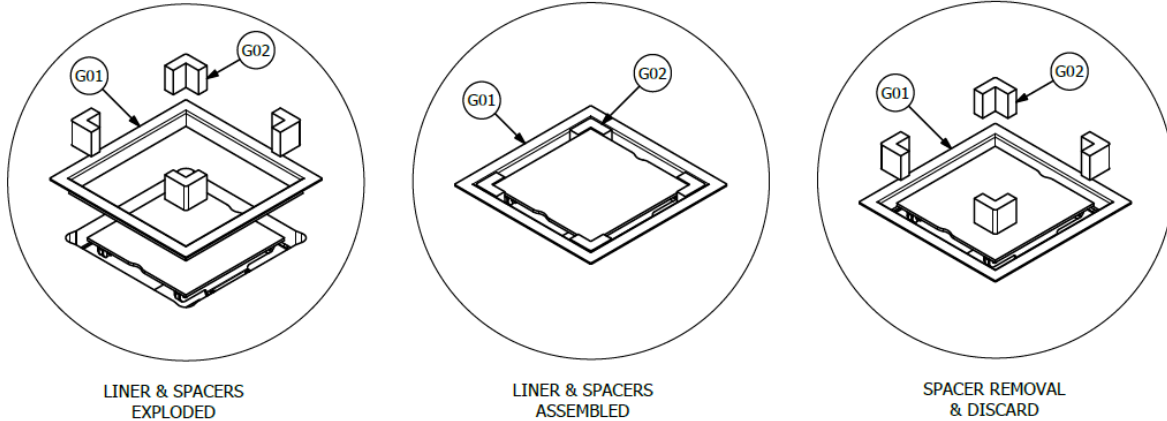

FIGURE 10: TOPMOUNT LINER ASSEMBLY

Table Leveling Check

1. With Top and Subtop attached, use Level to check and make sure table is still level.

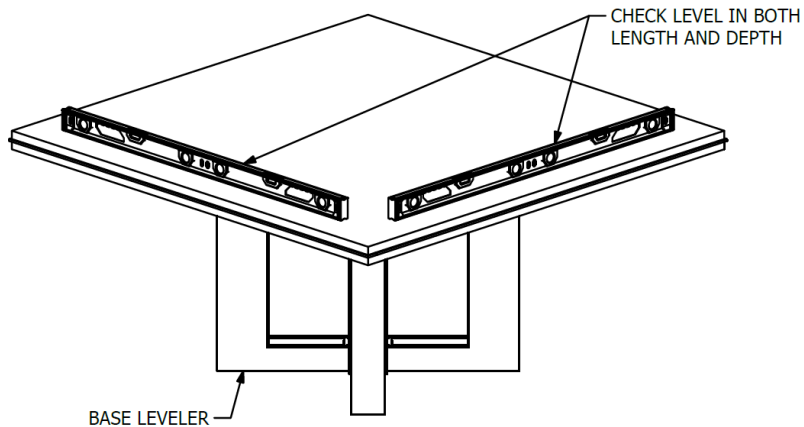

FIGURE 11: TABLE LEVELING CHECK

Instructions – Power & Connectivity

- For Unify Double-Sided Meeting Tabletop Power, refer to instruction 00D00015.
- For Unify Undermount Power, refer to instruction 00D00016.
- For Unify Edgemount Power, refer to instruction 00D00017.

Note:

- Power Drawers shipped pre-assembled to Subtop.

Assembly Instructions - Vertical Cable Management & Bottom Access Covers

1. Any cabling from the floor to the tabletop can be run thru the access channels in the Long Legs (A01\B01). See Figure 12.
2. After table assembly and/or cable management is complete, Bottom Access Covers (A03\B03) just drop into place. See Figure 13.

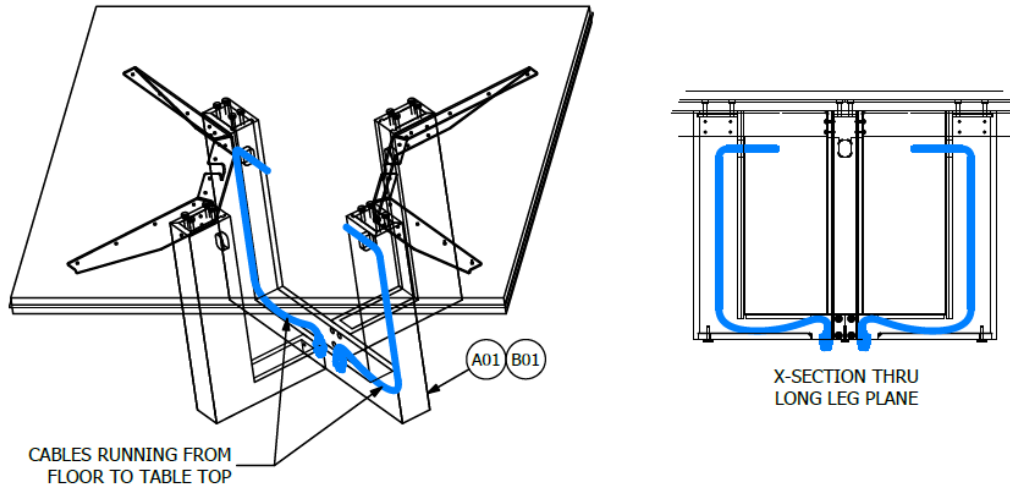

FIGURE 12: CABLE MANAGEMENT

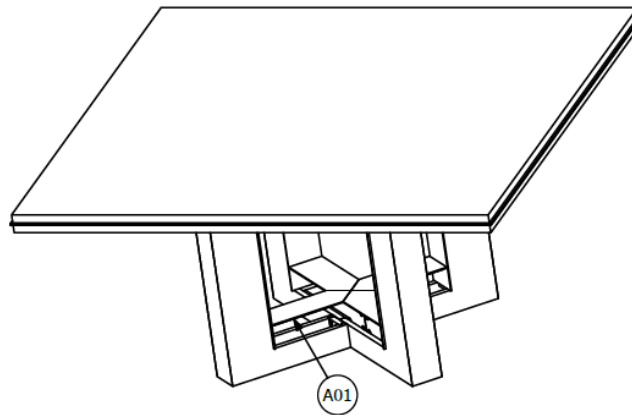

FIGURE 13: BOTTOM ACCESS COVER ASSEMBLY