

Instructions For Following Product(s)

- All standard Highline 25 Credenzas

Product(s) Required But Ordered Separately

- None

Related Instructions

- 02D00018 - Cabinet Door Hinge
- 02D00021 - Cabinet Drawer Slide
- 02D00020 - Cabinet Trash Drawer

Tools Required



Driver\Drill Gun



Tape Measure



Driver Bit,
Phillips #3

In The Box (Supplied By DatesWeiser)

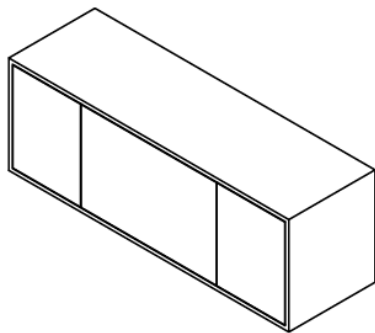

(A)
CREDENZA CASE

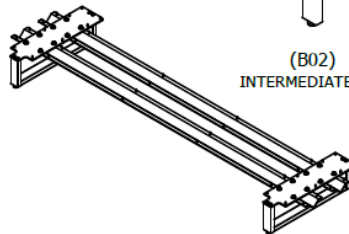

(B01)
BASE ASSEMBLY

(B) CREDENZA LEG



(B02)
INTERMEDIATE LEG



(B03)
WOOD SCREW
PAN HEAD PHILLIPS #12x3/4

(C) ACCENT TOPS

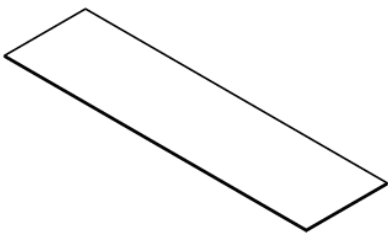

(C01)
FULL-LENGTH
(GLASS, STONE OR CORIAN)



(C02) *
BUMPER BS-05

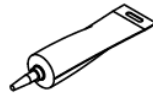

(C03) **
SILICONE TUBE

(D) PULLS

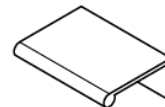

(D01)
TAB PULL



(D02)
WOOD SCREW
FLAT HEAD PHILLIPS #6x5/8

* FOR CLEAR GLASS
** FOR BACK-PAINTED GLASS, STONE OR CORIAN

Case & Leg Assembly

Note:

Completely assembled Credenzas are typically very heavy. Starting the assembly process as close as possible to its final position will make any re-positioning post assembly easier.

1. With Case (A) positioned up-side-down, secure Base Assembly (B01) using Fastener (B03). See Figure 01.
2. Credenzas optioned with Lateral Files, Refrigerators and/or AV Equipment will include one or more Intermediate Leg (B02). Using factory-drilled pilot holes for proper positioning, use Fastener (B03) to attach Intermediate Leg(s). See Figure 01.
3. Re-position Credenza with Legs assembled back into its proper up right orientation.

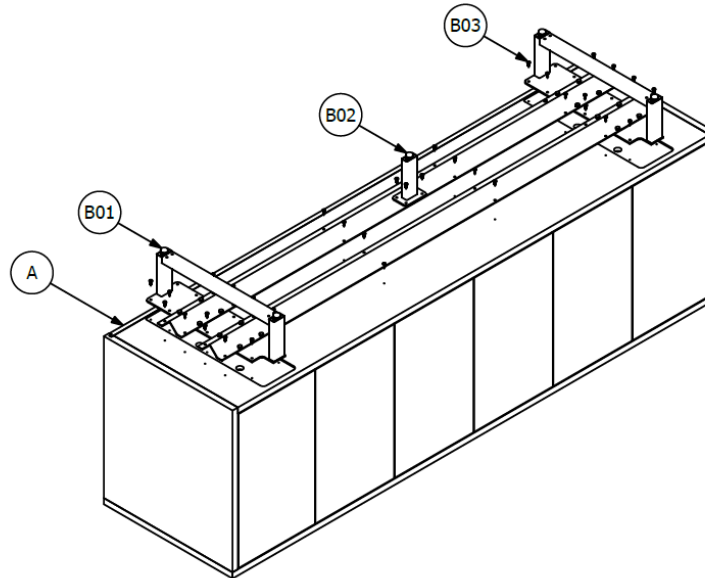

FIG. 01:
CASE & LEG ASSEMBLY

Pull Assembly (If Equipped)

Note:

Skip forward to "Position & Level" if Credenza is not equipped with Pulls.

1. Using Wood Screw D02, attach Pulls (D01) to Drawer Fronts. See Figure 02.

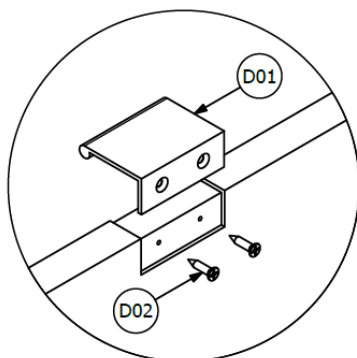

FIG. 02:
TAB PULL ASSEMBLY

Position & Level

1. With Credenza in its final position, use a level to adjust the leg levelers and level the Credenza. See Figure 03.

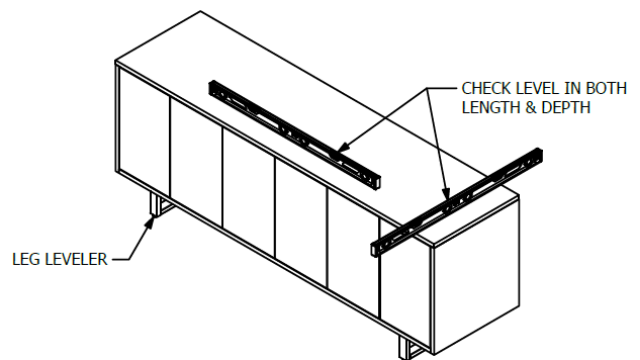

FIG. 03:
POSITION & LEVEL

Full-Length Top (If Equipped)

Note:

Assembly is complete if Credenza is not equipped with an Accent Top.

Clear Glass Only

1. Peel and stick Bumpers (C02), placing one in each corner of the Credenza inset approximately 2" to the center of the Bumper. Then (Spaced equally) stick the remaining bumpers along the length of the Credenza. See Figure 04.
2. Place Clear Glass Top (C01) on Bumpers, centered on Credenza and inset 1" on all sides. See Figure 04.

Back-Painted Glass, Stone or Corian

1. Using small dabs of Silicone (Y01) around the perimeter, secure Top (C01) centered on Credenza and inset 1" on all sides. See Figure 04.

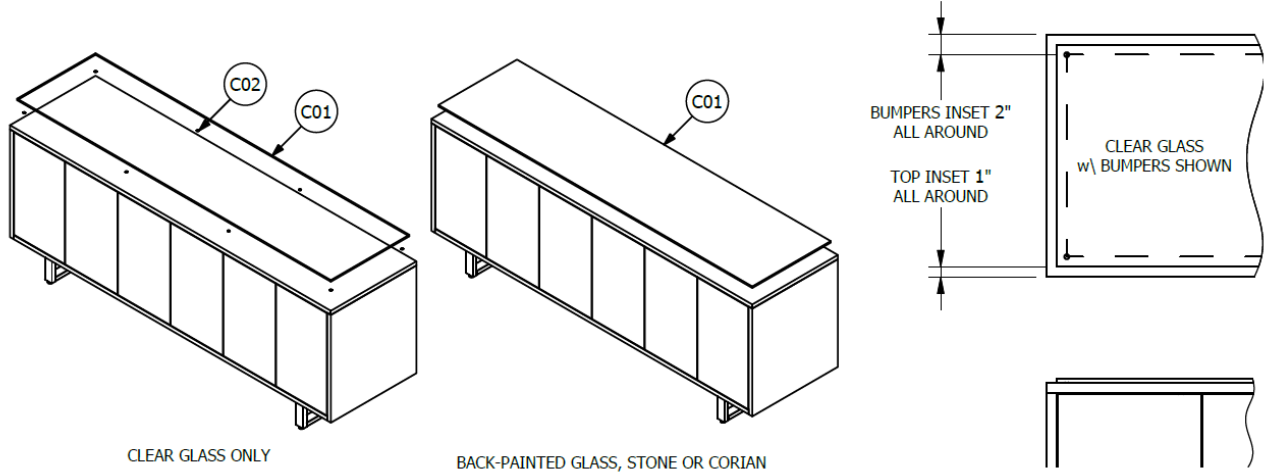

FIG. 04:
FULL-LENGTH TOP