

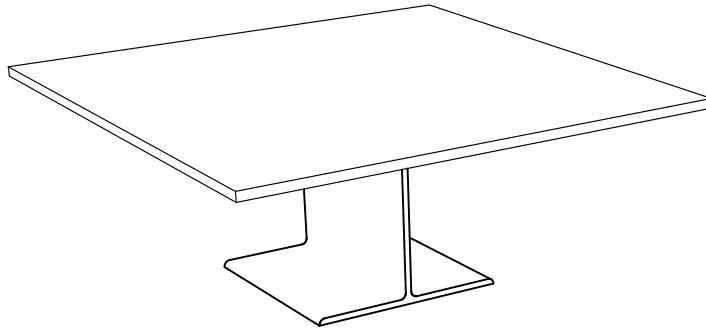

Parts List

Tools Required

- o Cordless Drill
- o Drill bits:
 - o #3 Phillips

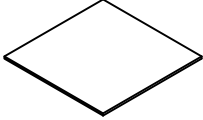
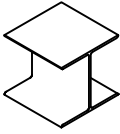
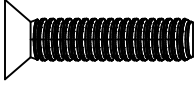

<p>Top (1x)</p> 	<p>Base (1x)</p> 	<p>1/4-20 x 1-1/8" Flat Head Machine Screw 1B862V (6x) for Stone Top Table</p> 	<p>1/2" Dia. x 1/8" Clear Bumper 51081 (8x) for Glass Top Table</p> 
---	--	--	---

1a. Stone Top Table

Set base in final location. Place stone top with 3/4" subtop on base so that holes on subtop align with the holes on the base. Attach top to base with # 3 philips head drill bit using six machine screws (1B862V).

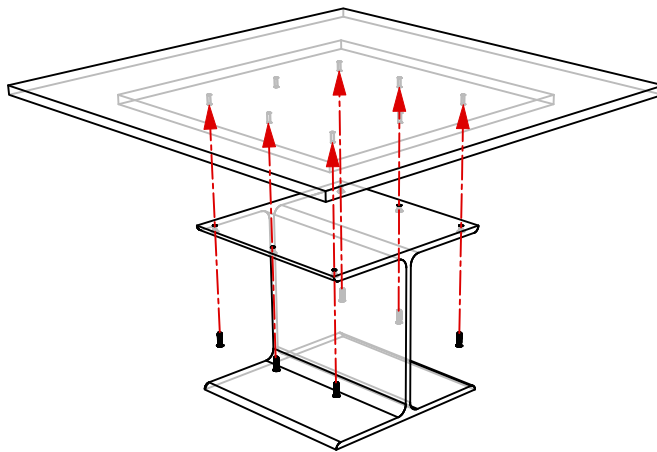

1b. Glass Top Table

Peel eight Clear bumpers (part 51081) from backer and place on base as shown below, about 1/2" in from base edges, aligning bumpers as neatly as possible. Place Glass Top on bumpers, centered over base

