



GSA prices effective October 7, 2024
(based on July 1, 2024, commercial price list)
Published April 2025

Laboratory Furniture Compass™ System

General Services Administration Federal Supply Service Authorized Federal Supply Schedule Price List

Online access to contract ordering information, terms and conditions, up-to-date pricing, and the option to create an electronic delivery order is available through GSA Advantage!®, a menu-driven database system. The Internet address for GSA Advantage! is www.gsaadvantage.gov.

Office Furniture
FSC/PSC 7110/7125
Contract Number: GS-03F-036DA
UEI: Q2K3MSZ843D8
Contract Period: December 21, 2015—December 20, 2025

MillerKnoll, Inc.
855 East Main Avenue
Zeeland, Michigan 49464
(616) 654 3000 Phone
(616) 654 8278 Fax
www.HermanMiller.com/government

Business Size: Large

Contract Information

1a. Special Item Numbers (SIN)

SIN 33721

Furniture Systems, Computer Furniture, Filing and Storage, Tables and Accessories, Upholstered Seating and Multi-Purpose Seating, Project Management, Reconfiguration and Relocation Services, Design/Layout and Installation Services

SIN 33721P

Packaged Offices

SIN 337127

Modular Laboratory Furniture Systems

SIN 339113H

Healthcare Furniture

SIN OLM

Order-Level Materials (OLMs)

This SIN is only for products and/or services used in direct support of the purchase of new furniture. It requires approval from the ordering Contract Officer. Please contact your local MillerKnoll Inc. representative to discuss the appropriate use of this SIN.

SIN 532289

Leasing

Contact MillerKnoll Inc participating government dealer for current leasing information.

1b. Lowest Priced Model

SIN 33721:	BVP3.S	\$7.27
SIN 33127:	TW113	\$5.81
SIN 339113H:	CR900NR	\$483.80

1c. Service Rates

Project Management

Furniture Project Manager: \$64.75 per hour
 Furniture Project Coordinator: \$49.00 per hour
 Build-Out Project Manager: \$80.00 per hour

Reconfiguration and Relocation Services

Not to exceed \$55 per hour.

See * Additional Notes for Installation & Reconfiguration and Relocation Services.

Design/Layout

Not to exceed \$65 per hour.

Installation Services

Not to exceed \$55 per hour (\$82.50 per hour for after-hours Installation).

See * Additional Notes for Installation & Reconfiguration and Relocation Services.

2. Maximum Order

SIN 33721, 337127, NEW, OLM

\$250,000 net product value

SIN 33721P

\$250,000 net value

SIN 339113H

\$500,000 net product value

3. Minimum Order

\$100 net

4. Geographic Coverage

Continental U.S.

Orders for Alaska, Hawaii, and Puerto Rico will be shipped F.O.B. inland carrier point of exportation.

5. Point of Production

Zeeland, Ottawa County, Michigan

Spring Lake, Ottawa County, Michigan

Elland, Yorkshire, United Kingdom

Hildebran, Burke County, North Carolina, USA

6. Pricing

Prices shown are list. Discounts include Industrial Funding Fee.

SIN 33721

Standard Lead Time, Single Order Net Purchase \$100 - 250,000, includes approved Herman Miller Options Products.

Product Line	Discount From List
Action Office 1	73.8%
Action Office 2	73.8%
Aeron	64.5%
Ambit Workspace Solutions	74.3%
Asari Chair	53.7%
Aside	64.2%
Bay Work Pod	56.7%
C-Style Overhead Storage	73.8%
Canvas Office Landscape Channel	74.8%
Canvas Office Landscape Dock	74.8%
Canvas Metal Desk	74.8%
Canvas Office Landscape Metal Storage	74.8%
Canvas Office Landscape Private Office	74.8%
Canvas Office Landscape Wood Storage	74.8%
Canvas Office Landscape Vista	74.8%
Canvas Office Landscape Wall	74.8%
Caper	61.5%
Commend Nurses Station	73.3%
Cosm	61.7%
Eames® Aluminum Group	58.7%
Eames Conference & Dining Tables	73.6%
Easton Family	54.91%
Embody	59.7%
Energy Distribution Systems	73.8%
Ethospace System	73.8%
Everywhere™ Tables	73.8%
Exclave	61.7%

Contract Information

continued

Fuld	59.7%
Headway™ Tables	73.8%
Intent Solution	58.7%
Layout Studio®	60.7%
Lighting	73.8%
Lino	63.7%
Meridian Laterals	67.3%
Meridian Pedestals	64.2%
Meridian Towers	62.7%
Meridian Storage	62.7%
Mirra 2	61.7%
Motia Tables	73.8%
NaughtOne	50.0%
Nemschoff	54.91%
Nevi™ Tables	73.8%
Nevi Link	73.8%
OE1 Boundary	72.8%
OE1 Community Elements	61.7%
OE1 Micro Packs	73.8%
OE1 Storage	72.8%
OE1 Tables and Benching	73.8%
Overlay™	62.7%
Plex® Lounge Furniture	59.5%
Pronta Stacking Chair	57.7%
Public Office Landscape	61.7%
Renew™ Tables	73.8%
Renew Link	73.8%
Sayl	62.2%
Setu	59.7%
Swoop Lounge Furniture	60.7%
Thrive Portfolio	62.0%
Thrive Portfolio-CBS Products Extension	62.0%
Tu Lateral Files	74.3%
Tu Pedestals	73.8%
Tu Storage	74.3%
Tu Towers	74.3%
Tu Wood Cases	74.3%
Tu Wood Cubbies	74.3%
Tu Wood Credenzas	74.3%
Tu Wood Pedestals	74.3%
Tu Wood Towers	74.3%
Valor™ Family	54.91%
Verus	63.7%
Zeph	60.2%

Services

Please refer to section 19 for Terms and Conditions of Installation/Reconfiguration and Relocation Services.

Project Management

Services under this SIN may be used only in conjunction with the purchase of new furniture. Please contact your local MillerKnoll Inc. representative to discuss the available labor categories (listed below). The hourly rates listed are "Not To Exceed" or "NTE" values.

Furniture Project Manager: \$64.75 per hour
 Furniture Project Coordinator: \$49.00 per hour
 Build-Out Project Manager: \$80.00 per hour

Reconfiguration and Relocation Services

Reconfiguration and Relocation Services will be provided by MillerKnoll Inc. or its participating dealer based on a fee not to exceed \$55 per hour.

See * Additional Notes for Installation & Reconfiguration and Relocation Services.

Design/Layout

Design service will be provided by MillerKnoll Inc. or its participating dealer based on a fee not to exceed \$65 per hour.

Installation Services

Installation Services will be provided by MillerKnoll Inc. or its participating dealer based on a fee not to exceed \$55 per hour (\$82.50 per hour for after-hours Installation).

See * Additional Notes for Installation & Reconfiguration and Relocation Services.

SIN 337127

Standard Lead Time, Single Order Net Purchase \$100 - 250,000, includes approved Herman Miller Options Products.

Product Line	Discount From List
Action Lab	58.5%
Compass System	58.5%
Co/Struc System	58.5%
Healthcare Carts	18.0%
Mora System	58.5%
Bedside Cabinets	58.5%

SIN 33721P

Packaged Office Furniture - Maximum Order \$250,000 (net).

Includes packaged furniture solutions for customers needing to furnish an office.

SIN 339113H

Standard Lead Time, Single Order Net Purchase \$100 - 500,000, includes approved Herman Miller Options Products.

Product Line	Discount From List
Nemschoff Healthcare Furniture	54.91%

7. Quantity Discounts

Reference item #6.

8. Payment Terms

Net 30 days

9. Foreign Items

None

10. Time of Delivery

- a. 90 day ARO
- b. Expedited delivery: Items listed in the 10-Day section of the catalogs are available for expedited delivery.
- c. Overnight/2-day delivery: Select items may be available for overnight or 2-day delivery. Contact MillerKnoll Inc. or a participating dealer for availability and rates.
- d. Urgent requirements: Agencies may contact contractor or participating dealer to request faster delivery.

Contract Information

continued

11. F.O.B.

F.O.B. destination except Alaska, Hawaii, and Puerto Rico, which will be shipped F.O.B. inland carrier point of exportation.

12. Ordering Address

- a. MillerKnoll Inc.
Government Customer Care 0161
855 East Main Avenue
Zeeland MI 49464.
- b. For supplies and services, the ordering procedures information on Blanket Purchase Agreements (BPA's) are found in Federal Acquisition Regulation (FAR) 8.405-3.

13. Payment Address.

MillerKnoll Inc.
22764 Network Place
Chicago, IL 60673-1227

14. Warranty

MillerKnoll Inc. commercial warranty applies.

15. Export Packing Charge

Prices supplied on request.

16. Rental Maintenance and Repair Terms

Not applicable

17. Terms and Conditions of Installation/Reconfiguration and Relocation Services

* Additional Notes for Installation & Reconfiguration and Relocation Services:

FOB Destination (Drop Ship): Price includes product delivery to the site, brought to the tailgate of the truck. The purchaser is responsible for unloading.

Prices effective up to the maximum order by SIN only. Above the MO, pricing shall be negotiated on a case-by-case basis between the client and local dealer.

Standard Services are Subject to the Following Conditions:

Installation will be performed during normal weekday working hours.

Adequate facilities for delivery, unloading, moving and staging/storing the product during the installation process shall be provided.

Service work will not be hindered by other trades.

Electric, heat, and adequate elevator service will be furnished without charge.

The immediate installation area shall be complete and free of debris including the carpet/flooring before installation commences.

Any work requiring a licensed electrician is the responsibility of the buyer.

Additional Charges May Apply For:

Major Metro Markets and any non-ground floor installation. Major Metro Markets include large population centers and urban environments.

Installation in a clinical/medical environment.

Special restrictions or limits established by local laws, ordinances or the directions of the buyer, including but not limited to restrictions on transportations of materials, street access to the job site and/or dock facilities.

Installations outside of a 50 mile radius of the servicing dealer.

Local Prevailing Wage and/or Union Labor Rates.

Any additional charges shall be quoted by the dealer and approved by the buyer prior to performance of the work.

18. Terms and Conditions of Repair Parts

Not applicable

19. Service and Distribution Points

For service and distribution points nearest you, call (800) 851 1196.

20. Participating Dealers

Access Herman Miller web site for current list of participating dealers: www.HermanMiller.com/where-to-buy/contact-a-dealer/. Select your market by using the filter.

21. Preventive Maintenance

Not applicable

22a. Special Attributes.

2021

The OE1 Trolley and Micro Packs are both winners of the 2021 Archiproducts international design competition in the Office Category.

MillerKnoll is named to Michigan's Best and Brightest in Wellness List for 2021.

OE1 is named winner of Wallpaper's "Most Futuristic Furniture" Category as part of their first-ever Smart Space Awards.

OE1 receives the Workplace category award from Fast Company's 2021 Innovation by Design Awards.

MillerKnoll is named to Fast Company's Annual List of the World's Most Innovative Companies for 2021.

MillerKnoll is recognized as a "Disclosure Leader" by the Chemical Footprint Project (CFP).

MillerKnoll is named to Newsweek's List of America's Most Responsible Companies 2021.

Contract Information

continued

2020

Herman Miller is recognized with a 2020 FSC® Leadership Award for our commitment to responsible forestry management.

Working Mother names Herman Miller as one of the Best Companies for Dads.

Cosm, by Studio 7.5, receives an iF Gold Award in the Office and Industry category at the iF World Design Awards 2020.

2019

Mora System casework, designed by Collective Ten for Herman Miller, receives silver in the Industrial and Life Science Design/ Medical Furniture category at the European Product Design Awards.

Mora System casework is awarded GOOD DESIGN Award 2019, selected for design excellence and innovation.

TIME Magazine names Cosm to its list of 100 Best Inventions of 2019.

Herman Miller is recognized as a silver level Certified Veteran-Friendly Employer by the Michigan Veterans Affairs Agency for a commitment to veteran hiring, retention, and development.

Herman Miller is named "Frontrunner" in Chemical Footprint Project by Clean Production Action for our chemical management policies and practices.

Herman Miller receives International Interior Design Association and Contract's best showroom design award in the "Large Showroom" category at NeoCon.

Cosm, designed by Studio 7.5 for Herman Miller, receives a Red Dot Best of the Best Product Design Award in the "Office Chairs" category.

Lino, designed by Sam Hecht and Kim Colin for Herman Miller, receives an iF Design Award in the Product Design category.

2018

Overlay, designed by Birsell+Seck, receives Interior Design Best of Year Award in the Partitions and Wall Systems category.

Herman Miller receives Gold Medal from EcoVadis in recognition of Corporate Social Sustainability achievement measured in categories of environment, labor and human rights, ethics, and sustainable procurement. EcoVadis operates the first web-based collaborative platform that allows companies to assess the environmental and social performance of their global suppliers.

Aeron receives Good Design Award from The Chicago Athenaeum Museum of Architecture and Design.

The Cosm Chair wins Mix Interiors "Product of the Year—Task" award.

2017

Herman Miller receives "Rising Star Award" from the Michigan Veterans Affairs Agency (MVAA) for exhibiting new and novel approaches to veteran recruitment and hiring.

Herman Miller receives a 2017 SEAL (Sustainability, Environmental Achievement and Leadership) Business Sustainability Award. SEAL Award winners are determined by a holistic methodology measuring applicants against established benchmarks that demonstrate impact and progress toward creating a healthy planet and a sustainable future.

Herman Miller is named one of the Best and Brightest in Wellness for the 5th year in a row.

Herman Miller once again earns the WorldatWork Seal of Distinction, a unique standard of excellence in work-life effectiveness that shows we provide a distinct, mutually beneficial workplace experience. Herman Miller is the only furniture manufacturer among the 160 companies across the U.S. and Canada honored with the award.

Herman Miller's Mora wins Nightingale Silver Award in the "Furniture Collections" category at the 2017 Healthcare Design Conference.

2016

Herman Miller is recognized as the Business of the Year at the Annual Meeting of the West Michigan Environmental Action Council (WMEAC) for being an outstanding partner in support of the growth of WMEAC's programs. WMEAC's award goes to the business with the greatest depth and breadth of support, unwavering dedication to environmental action in West Michigan, and a strong corporate commitment to environmental advocacy.

The 101 Best and Brightest Sustainable Companies once again (5th consecutive year) recognizes Herman Miller as an organization in Michigan (and for the first time, in the nation) that exhibits leadership and innovation in its approach to sustainability. This award celebrates those companies that are making their businesses more sustainable, the lives of their employees better, and the community, both locally and globally, more responsible as a whole.

Herman Miller is recognized as a 2016 Healthiest 100 Workplace in America, ranking 49th in the country for our commitment to health and exceptional corporate wellness programming.

Herman Miller receives the Best and Brightest in Wellness Award for the 4th year in a row. This program is an innovative initiative that recognizes and celebrates quality and excellence in health awareness.

The Michigan Occupational Safety and Health Administration renews Herman Miller's "Star" status, the highest workplace safety and health designation, for the Hickory facility in Spring Lake.

Contract Information

continued

Plex Lounge Furniture from Herman Miller receives #MetropolisLikes award at NeoCon 2016.

Plex Lounge Furniture from Herman Miller receives Interior Design HIP Award for Workplace Seating/Lounge at NeoCon 2016.

Herman Miller again earns the WorldatWork Work-Life 2016 Seal of Distinction. This award identifies organizations that focus on programs that promote work-life balance and overall well-being.

22b. Section 508 Compliance

Not applicable

23. Unique Entity ID: Q2K3MSZ843D8

24. Registered in System for Award Management (www.SAM.gov) Database

25. Cancellation

Prior to production, no cancellation charge will apply. After production, only actual cost incurred that the contractor can demonstrate if items are sold after 3 months.

26. Restocking Charges

Agencies must notify the contractor for authorization prior to returning any items. The customer agency will be required to pay all packaging and return freight charges. A restocking fee of 50% for Systems Furniture and 35% for all other product lines will be charged for any returned items.

Returns and restocking policy is not applicable to Options products, products under SIN 337127, 339113H, NaughtOne and Nemschoff products.

MillerKnoll Inc. Miscellaneous Information:

Federal ID Number: 38-0837640

Commercial and Government Entity Code (CAGE): 40636

Data Universal Numbering System (DUNS) 00-601-2801

Commercial Entity Code (CEC): 00702290J

Introduction	page 2
Compass™ System	3
Walls	5
Surfaces	39
Storage	57
Close-Outs	83
Transport	89
Rails and Accessories	93
Indices	109
By Name	109
By Number	111
Appendices	
20-Day or Less/Assigned Lead-Time Order Information - Healthcare	
For the latest materials information, refer to the Materials pages on HermanMiller.com.	

Introduction

A Note on the Organization of This Book

There are a few signals that will help you understand the organization of this book. Once you know them, you should be able to find your way around easily.

Like a newspaper, this book is formatted with columns of text and illustrations that run vertically.

Information wraps from one column to the next and continues for as many pages as it needs to.

Black bars are clues.

A black bar at the top of a page signals the start of information about a product.

This information is divided into two sections, each signaled by a black bar. Product Information includes a description, additional notes, and dimensional drawings. Specification Information, which always begins at the top of a column, includes a series of steps. Each step represents a decision you need to make in order to complete your product number. Steps must be followed sequentially. The number of pages needed to complete information on a product varies; some will be complete in one page; others may fill three or four pages. Just continue going through the steps until you run into the next product, signaled by the black bar at the top of the page.

Black tabs running along the outside edge of the page help you locate what section you are in or what section you want to go to. You can thumb forwards or backwards to find a section; tabs and text appear on both sides of the page.

The additional pages in the back of the book include the appendices and indices. They are signaled by a long black bar running along the outside edge of the page.

The index is presented two ways.

The first index is in alphabetical order by product name. It can be helpful if you are new to the products and numbering scheme or if you are looking for a type of product, such as work chair or round table.

The second index is by product number. It lists, in alphanumeric order, the base product number, typically a five-digit number.

General Information

This book is effective October 7, 2024, subject to change without notice. Products may be purchased from authorized Herman Miller dealers who will quote prices upon request. For more information about our products and services or to see a list of dealers, visit www.HermanMiller.com.

All prices are list prices. Additional services, such as planning services, design, storage, and installation, are not included and must be added to these prices when the additional services are requested.

Illustrations, specifications, and prices are based on the latest information at the time of publication. The right is reserved to make changes at any time without notice in prices, fabrics, finishes, materials, specifications, and models, and also to discontinue models and finishes.

Dimensions shown in the drawings are engineering drawing dimensions rounded up to the nearest $\frac{1}{8}$ ". Product is shipped set up or knocked down. Products that include "Shipped knocked down" in the description require some assembly. If this statement does not appear in the description, the product is shipped assembled.

Service problems are normally handled by a Herman Miller authorized dealer. Where this cannot be accomplished on a local level, service problems should be referred to the Customer Care Representative for your region, Herman Miller, Inc., Zeeland, Michigan 49464.

20-Day or Less/Assigned Lead-Time Shipments

All products and options in this price book not designated by an Assigned Program icon  will ship in **20 business days or less** after being acknowledged by Herman Miller.

Products and options designated by an  are on the assigned lead-time program and may ship in 20 days, less than 20 days, or more than 20 days from order acknowledgement.

Walls

Surfaces

Storage

Close-Outs

Transport

Rails and Accessories



Wall Rail

TW100.

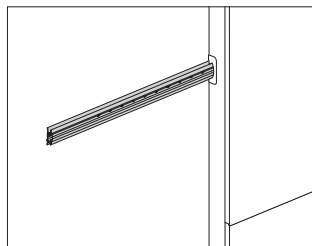

Product Information

Description

This rail attaches to an architectural wall to support stiles for attaching tiles and components. The rail does not require attaching to wall studs; it attaches directly to finished 5/8"-thick or thicker drywall using wall anchors specified separately. Finish is anodized aluminum.

Notes

Specify wall anchors (TW109.) separately.

Specify optional products separately:

- Wall Rail End Cap (TW104.)
- Wall Rail Insert (TW102.)

Dimensions

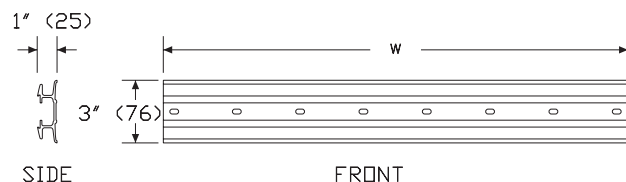

Specification Information

Step 1.

TW100.

Step 2. Width

18	18" wide
24	24" wide
30	30" wide
36	36" wide
42	42" wide
48	48" wide
54	54" wide
60	60" wide
66	66" wide
72	72" wide
78	78" wide
84	84" wide
96	96" wide

Prices for Steps 1-2.

TW100. 18	\$52
24	\$65
30	\$75
36	\$88
42	\$99
48	\$109
54	\$121
60	\$134
66	\$147
72	\$153
78	\$166
84	\$177
96	\$200

Wall Rail Insert

TW102.

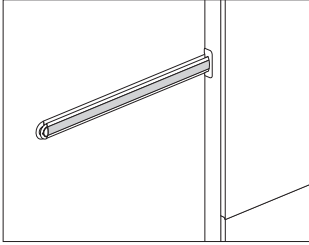

Compass™ Walls

Product Information

Description

This individual insert fits into a wall rail to finish the front and conceal the mounting screws. The insert can be cut to length in the field. Finish is cool grey neutral.

Dimensions



Specification Information

Step 1.

TW102.

Step 2. Width

48	48" wide
96	96" wide

Prices for Steps 1-2.

TW102. 48	\$40
96	\$59

Wall Rail End Cap

TW104.

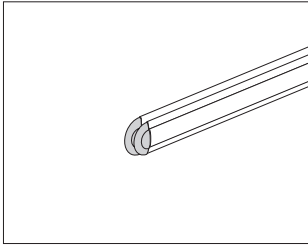

Product Information

Description

This end cap attaches to a wall rail to finish the end when the rail is exposed. It has a metallic silver plate with a cool grey neutral cover. Package of 2.

Dimensions

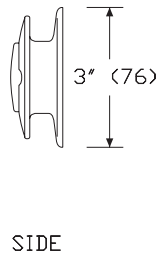
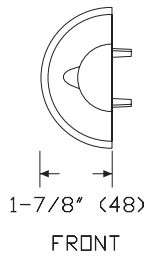
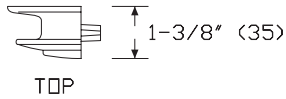

Specification Information

Step 1.

TW104.

\$168

Wall Anchors

TW109.

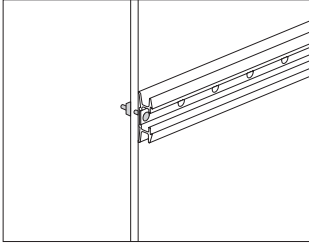

Compass™ Walls

Product Information

Description

These anchors attach a wall rail to an architectural wall. Anchors are required every 6" along the entire length of the wall rail, and allow the rail to attach to 5/8" thick or thicker drywall, without having to attach to wall studs. Package of 100.

Dimensions

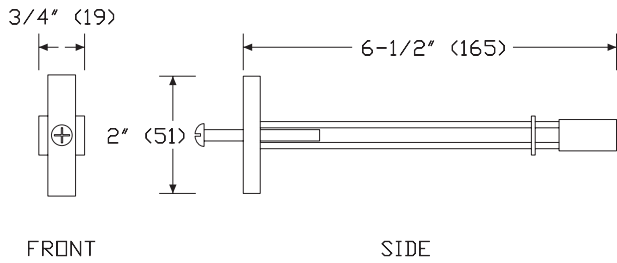

Specification Information

Step 1.

TW109.

\$311

Stile, Rail-Attached

TW110.

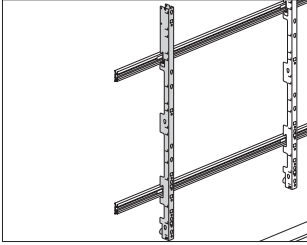

Product Information

Description

This individual stile mounts on wall rails. 2 stiles are required for attaching tiles and components, creating a module. Multiple modules can be placed on the wall rails to finish a wall. The stile has cutouts for routing cables and conduit, and includes anti-dislodgement clips.

Notes

Specify stile connector kit (TW113.) separately to minimize gaps between adjacent tiles and components.

Specify 64"-high stiles for mounting on 2 wall rails to create a full-height module.

Specify 24"-high stiles for mounting on 1 wall rail to create a lower module.

Dimensions

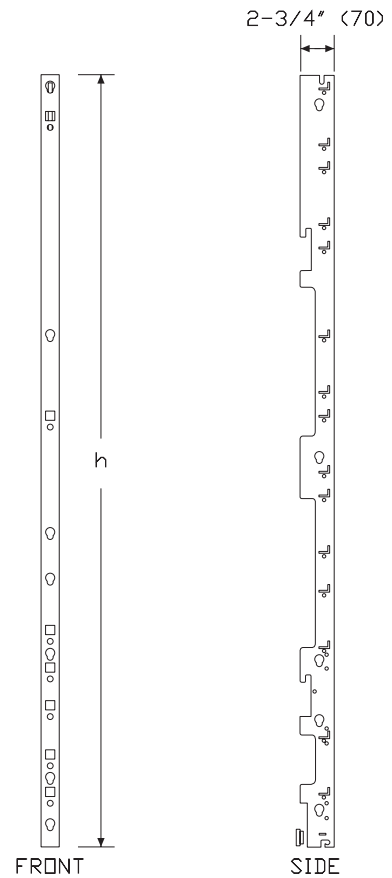
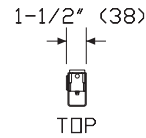

Specification Information

Step 1.

TW110.

Step 2. Height

24 24" high

64 64" high

Prices for Steps 1-2.

TW110. 24	\$90
64	\$101

Stile Lockdown

TW112.

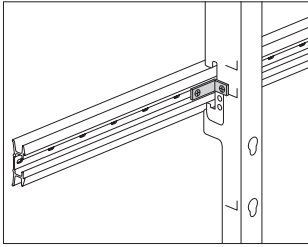

Product Information

Description

This hardware locks a stile in place on the wall rail(s) to eliminate movement. 1 lockdown is required per wall application.

Dimensions

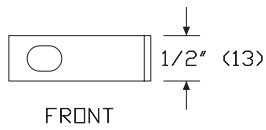
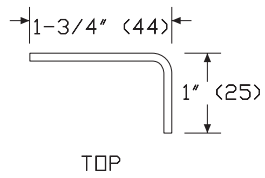

Specification Information

Step 1.

TW112.

\$24

Stile Connector Kit

TW113.

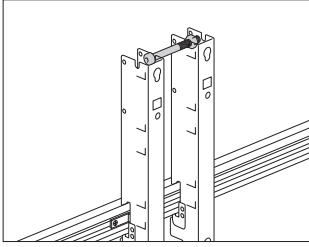

Compass™ Walls

Product Information

Description

This kit connects 2 adjacent stiles at the top and bottom to provide alignment and minimize gaps when tiles and components are attached. Package of 2.

Dimensions

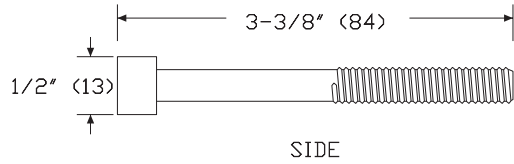

Specification Information

Step 1.

TW113.

\$14

Stile, Chase Tile

TW114.

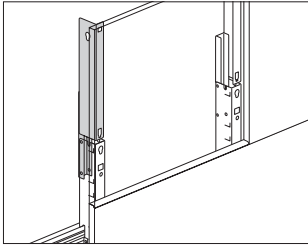

Product Information

Description

This individual stile attaches to the top of a rail-attached stile. 2 stiles are required for attaching a chase tile. Attachment hardware included.

Notes

Specify chase tile (TW182.) separately.

Dimensions

Specification Information

Step 1.

TW114.

Step 2. Type

- L left
- R right

Prices for Steps 1-2.

TW114. L	\$109
R	\$109

Compass™ Walls

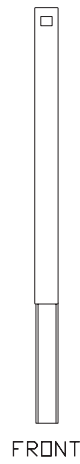
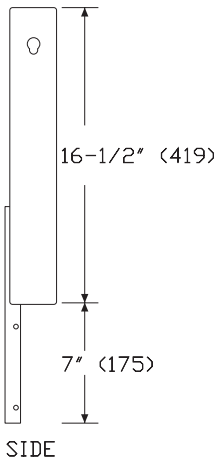
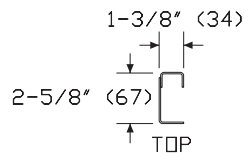

Face Tile

TW120.

Compass™ Walls

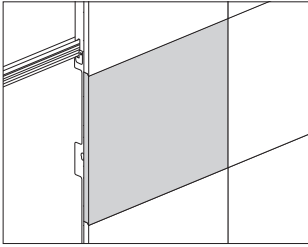

Product Information

Description
 This tile attaches to 2 rail-attached stiles to provide a finished cover and is available in durawrap. The top and bottom edges are ship lapped (shingled); creating a flush joint between tiles that prevents liquids from seeping back.

Dimensions

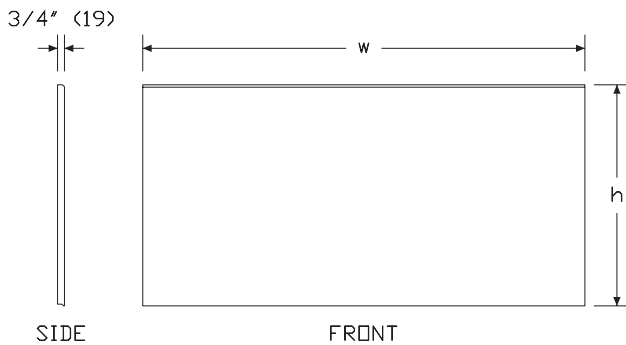

Specification Information

Step 1.

TW120.

Step 2. Height

- 20 20" high
- 24 24" high
- 40 40" high

Step 3. Width

- 12 12" wide
- 18 18" wide
- 24 24" wide
- 30 30" wide
- 36 36" wide
- 42 42" wide
- 48 48" wide

Step 4. Surface Material

For 20" high (20) or 24" high (24)

- A durawrap™ 3D laminate
- P 3D laminate

For 40" high (40)

- A durawrap™ 3D laminate
- P 3D laminate

Prices for Steps 1-4.

			A	P
TW120.	20	12	\$212	194
		18	\$224	207
		24	\$236	218
		30	\$268	243
		36	\$300	274
		42	\$346	318
		48	\$394	361
	24	12	\$227	209
		18	\$242	224
		24	\$259	237
		30	\$286	260
		36	\$308	280
		42	\$355	326
		48	\$404	369

Face Tile *continued*

40	12	\$341	312
	18	\$368	338
	24	\$394	361
	30	\$450	413
	36	\$504	463
	42	\$552	501
	48	\$595	541

Step 5. Surface Finish

Solid-Color

For durawrap™ 3D laminate (A)

91	white (CP)	+\$0
LU	soft white	+\$0

Wood-Grain

For durawrap™ 3D laminate (A)

LBA	clear on ash (CP)	+\$10
LBB	oak on ash (CP)	+\$10
LBC	walnut on ash (CP)	+\$10
LBU	medium matte walnut (CP)	+\$10

For 3D laminate (P)

120	light maple woodgrain 3D laminate <input type="checkbox"/>	+\$0
121	golden maple woodgrain 3D laminate <input type="checkbox"/>	+\$0
122	brown walnut woodgrain 3D laminate <input type="checkbox"/>	+\$0
125	light teak woodgrain 3D laminate <input type="checkbox"/>	+\$10
126	basic white 3D laminate <input type="checkbox"/>	+\$0

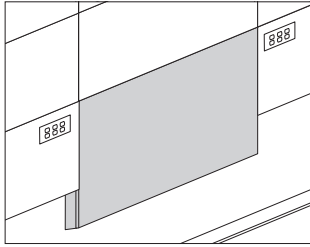

Product Information

Description

This tile attaches to 2 rail-attached stiles to provide a finished cover and has a durawrap surface. It protects the architectural wall from being damaged due to contact with a bed. The top edge is ship lapped (shingled); creating a flush joint between tiles that prevents liquids from seeping back. Side close-outs and a wall saver to protect the architectural wall behind the tile are included.

Notes

Bottom close-out finish always in soft white (LU).

Dimensions

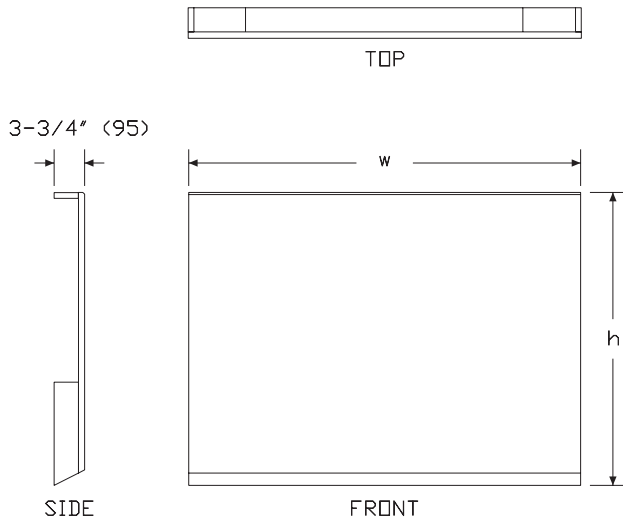

Specification Information

Step 1.

TW122. [A]

Step 2. Height

- 36** 36" high [A]
- 39** 39" high [A]

Step 3. Width

- 36** 36" wide
- 48** 48" wide

Step 4. Surface Material

- A** durawrap™ 3D laminate
- P** 3D laminate [A]

Prices for Steps 1-4.

			A	P
TW122.	36	36	\$889	737
		48	\$942	857
	39	36	\$1023	913
		48	\$1081	997

Step 5. Close-Out Finish

- 91** white (CP) +\$0
- LU** soft white +\$0

Step 6. Surface Finish

Solid-Color

For durawrap™ 3D laminate (A)

- 91** white (CP) +\$0
- LU** soft white +\$0

Wood-Grain

For durawrap™ 3D laminate (A)

- LBA** clear on ash (CP) +\$10
- LBB** oak on ash (CP) +\$10
- LBC** walnut on ash (CP) +\$10
- LBU** medium matte walnut (CP) +\$10

For 3D laminate (P)

- 120** light maple woodgrain 3D laminate [A] +\$0
- 121** golden maple woodgrain 3D laminate [A] +\$0
- 122** brown walnut woodgrain 3D laminate [A] +\$0
- 125** light teak woodgrain 3D laminate [A] +\$10
- 126** basic white 3D laminate [A] +\$0

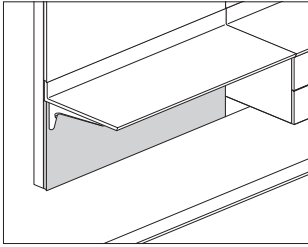

Product Information

Description

This tile attaches to 2 rail-attached stiles to provide mounting of a work surface and has a 3D laminate surface. Durawrap™ 3D laminate is a 99.9% PVC-free material. It has partially-drilled holes in the back for seated-height and standing-height surfaces. The top and bottom edges are ship lapped (shingled); creating a flush joint between tiles that prevents liquids from seeping back.

Dimensions

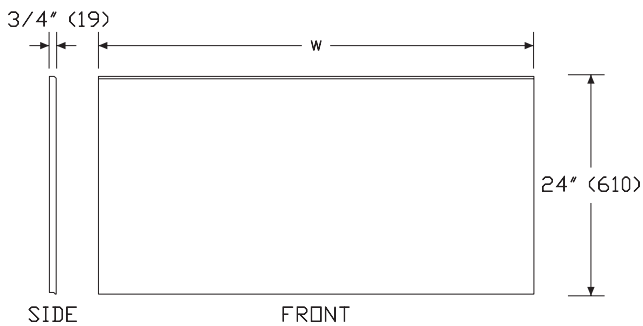

Specification Information

Step 1.

TW124.

Step 2. Width

12	12" wide
18	18" wide
24	24" wide
30	30" wide
36	36" wide
42	42" wide
48	48" wide

Step 3. Work Surface Type

AW	seated height with backsplash
BW	standing height with backsplash
CN	standing or seated height, no backsplash

Step 4. Surface Material

A	durawrap™ 3D laminate
P	3D laminate <input type="checkbox"/> A

Prices for Steps 1-4.

		A	P
TW124. 12	AW	\$175	161
	BW	\$302	263
	CN	\$350	321
18	AW	\$178	162
	BW	\$282	276
	CN	\$346	318
24	AW	\$205	180
	BW	\$308	280
	CN	\$376	345
30	AW	\$233	217
	BW	\$345	298
	CN	\$422	387
36	AW	\$292	268
	BW	\$367	317
	CN	\$472	430
42	AW	\$280	256
	BW	\$345	317
	CN	\$469	428
48	AW	\$315	290
	BW	\$377	346
	CN	\$509	470

Work Surface Tile *continued*

Compass™ Walls

Step 5. Surface Finish

Solid-Color

For durawrap™ 3D laminate (A)

91	white (CP)	+\$0
LU	soft white	+\$0

Wood-Grain

For durawrap™ 3D laminate (A)

LBA	clear on ash (CP)	+\$10
LBB	oak on ash (CP)	+\$10
LBC	walnut on ash (CP)	+\$10
LBU	medium matte walnut (CP)	+\$10

For 3D laminate (P)

120	light maple woodgrain 3D laminate <input type="checkbox"/> A	+\$0
121	golden maple woodgrain 3D laminate <input type="checkbox"/> A	+\$0
122	brown walnut woodgrain 3D laminate <input type="checkbox"/> A	+\$0
125	light teak woodgrain 3D laminate <input type="checkbox"/> A	+\$10
126	basic white 3D laminate <input type="checkbox"/> A	+\$0

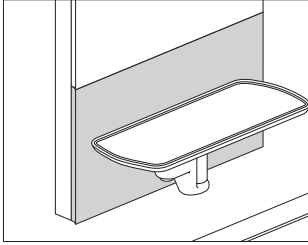

Product Information

Description

This tile attaches to 2 rail-attached stiles to provide mounting of a rotating work surface. It has a durawrap finish.

Dimensions

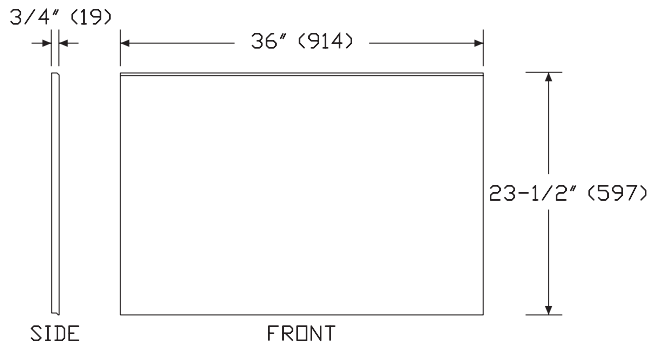

Specification Information

Step 1.

TW126.2436

Step 2. Surface Material

- A** durawrap™ 3D laminate
- P** 3D laminate

Prices for Steps 1-2.

TW126.2436	A	\$326
	P	\$298

Step 3. Surface Finish

Solid-Color

For durawrap™ 3D laminate (A)

91	white (CP)	+\$0
LU	soft white	+\$0

Wood-Grain

For durawrap™ 3D laminate (A)

LBA	clear on ash (CP)	+\$10
LBB	oak on ash (CP)	+\$10
LBC	walnut on ash (CP)	+\$10
LBU	medium matte walnut (CP)	+\$10

For 3D laminate (P)

120	light maple woodgrain 3D laminate <input type="checkbox"/>	+\$0
121	golden maple woodgrain 3D laminate <input type="checkbox"/>	+\$0
122	brown walnut woodgrain 3D laminate <input type="checkbox"/>	+\$0
125	light teak woodgrain 3D laminate <input type="checkbox"/>	+\$15
126	basic white 3D laminate <input type="checkbox"/>	+\$0

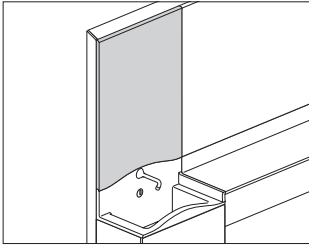

Product Information

Description
 This tile attaches to 2 rail-attached stiles to finish the area above a 13" deep sink. The bottom of the tile is contoured to match the backsplash of the sink. It is available in 3D laminate or Corian®. Durawrap™ 3D laminate is a 99.9% PVC-free material. The top and bottom edges are ship lapped (shingled); creating a flush joint between tiles that prevents liquids from seeping through.

Dimensions

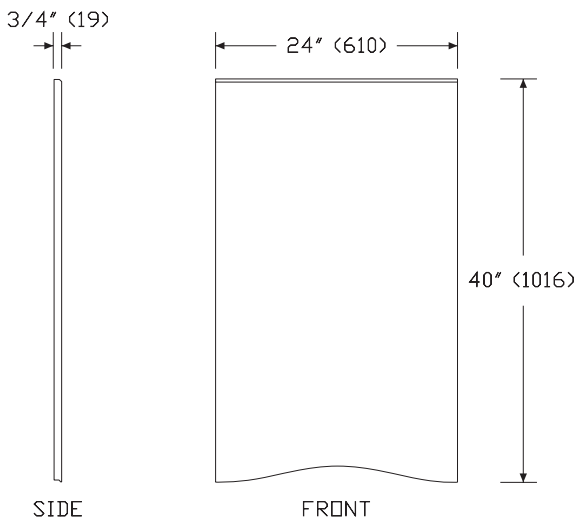

Specification Information

Step 1.

TW128.

Step 2. Height

- 20** 20" high
- 40** 40" high

Step 3. Surface Material

For 20" high (20)

- A** durawrap™ 3D laminate
- K** corian
- P** 3D laminate

For 40" high (40)

- A** durawrap™ 3D laminate
- P** 3D laminate

Prices for Steps 1-3.

	A	K	P
TW128. 20	\$229	842	212
40	\$405	—	370

Step 4. Surface Finish

Solid-Color

For durawrap™ 3D laminate (A)

- 91** white (CP) +\$0
- LU** soft white +\$0

Wood-Grain

For durawrap™ 3D laminate (A)

- LBA** clear on ash (CP) +\$10
- LBB** oak on ash (CP) +\$10
- LBC** walnut on ash (CP) +\$10
- LBU** medium matte walnut (CP) +\$10

Above-Sink Tile *continued*

For corian (K)

CQ	glacier white	+\$0
QB	bisque	+\$0
58	cameo white	+\$0
1S	savannah	+\$50
1U	sahara	+\$50
4I	sandstone	+\$50
OQ	silt	+\$50
ANC	antarctica	+\$50
SVG	silver gray	+\$50
CRT	concrete	+\$120
DVC	dove	+\$120

For 3D laminate (P)

120	light maple woodgrain 3D laminate <input type="checkbox"/> A	+\$0
121	golden maple woodgrain 3D laminate <input type="checkbox"/> A	+\$0
122	brown walnut woodgrain 3D laminate <input type="checkbox"/> A	+\$0
125	light teak woodgrain 3D laminate <input type="checkbox"/> A	+\$10
126	basic white 3D laminate <input type="checkbox"/> A	+\$0

Above-Sink Tile, ADA-Compliant Sink TW129.

Compass™ Walls

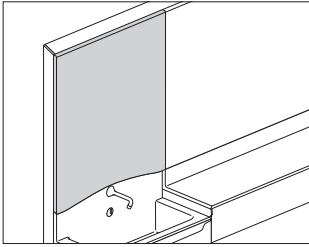

Product Information

Description
 This Sink Tile attaches to two Rail-Attached Stiles, ordered separately. It has shingled, creating a flush join between tiles that prevents liquids from seeping through.

Dimensions

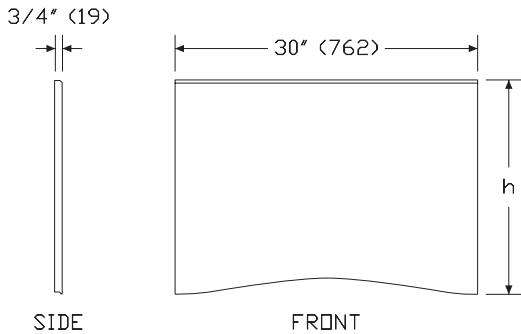

Specification Information

Step 1.

TW129.

Step 2. Height

- 20 20" high
- 40 40" high

Step 3. Width

- 30 30" wide

Step 4. Surface Material

For 20" high (20)

- A durawrap™ 3D laminate
- K corian
- P 3D laminate

For 40" high (40)

- A durawrap™ 3D laminate
- P 3D laminate

Prices for Steps 1-4.

			A	K	P
TW129.	20	30	\$329	971	302
	40	30	\$661	—	604

Step 5. Surface Finish

Solid-Color

For durawrap™ 3D laminate (A)

- 91 white (CP) +\$0
- LU soft white +\$0

Wood-Grain

For durawrap™ 3D laminate (A)

- LBA clear on ash (CP) +\$10
- LBB oak on ash (CP) +\$10
- LBC walnut on ash (CP) +\$10
- LBU medium matte walnut (CP) +\$10

Above-Sink Tile, ADA-Compliant Sink

continued

For corian (K)

CQ	glacier white	+\$0
QB	bisque	+\$0
58	cameo white	+\$0
1S	savannah	+\$50
1U	sahara	+\$50
4I	sandstone	+\$50
IQ	aurora	+\$50
OQ	silt	+\$50
ANC	antarctica	+\$50
SVG	silver gray	+\$50
CRT	concrete	+\$120
DVC	dove	+\$120

For 3D laminate (P)

120	light maple woodgrain 3D laminate <input type="checkbox"/> A	+\$0
121	golden maple woodgrain 3D laminate <input type="checkbox"/> A	+\$0
122	brown walnut woodgrain 3D laminate <input type="checkbox"/> A	+\$0
125	light teak woodgrain 3D laminate <input type="checkbox"/> A	+\$10
126	basic white 3D laminate <input type="checkbox"/> A	+\$0

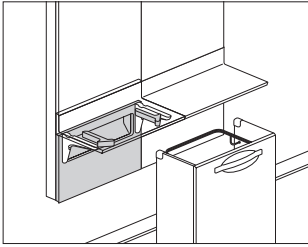

Product Information

Description
 This tile attaches to 2 rail-attached stiles below a work surface to provide a docking area for a linen cart. It includes 2 guides that attach to the work surface support brackets to help align the cart in its stored position. The top and bottom edges are ship lapped (shingled); creating a flush joint between tiles that prevents liquids from seeping back.

Notes

Order cantilever (TW219.) separately. Linen cart guides will attach to work surface support brackets.

Dimensions

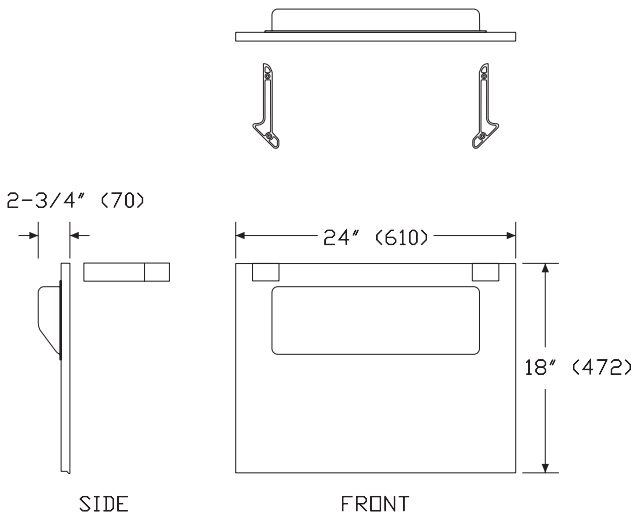

Specification Information

Step 1.

TW130.

Step 2. Work Surface Type

- BW** work surface with backsplash
- CN** work surface without backsplash

Step 3. Surface Material

- A** durawrap™ 3D laminate
- P** 3D laminate

Prices for Steps 1-3.

	A	P
TW130. BW	\$560	528
CN	\$644	612

Step 4. Surface Finish

Solid-Color

For durawrap™ 3D laminate (A)

91	white (CP)	+\$0
LU	soft white	+\$0

Wood-Grain

For durawrap™ 3D laminate (A)

LBA	clear on ash (CP)	+\$10
LBB	oak on ash (CP)	+\$10
LBC	walnut on ash (CP)	+\$10
LBU	medium matte walnut (CP)	+\$10

For 3D laminate (P)

120	light maple woodgrain 3D laminate <input type="checkbox"/>	+\$0
121	golden maple woodgrain 3D laminate <input type="checkbox"/>	+\$0
122	brown walnut woodgrain 3D laminate <input type="checkbox"/>	+\$0
125	light teak woodgrain 3D laminate <input type="checkbox"/>	+\$10
126	basic white 3D laminate <input type="checkbox"/>	+\$0

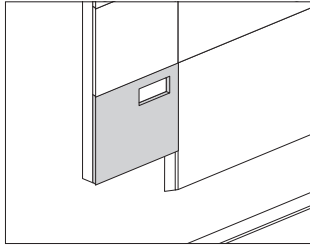

Product Information

Description

This tile attaches to 2 rail-attached stiles in the lowest position and has cutouts for various combinations of electrical access. The top and bottom edges are ship lapped (shingled); creating a flush joint between tiles that prevents liquids from seeping back. The tile has a 3D laminate surface. Durawrap™ 3D laminate is a 99.9% PVC-free material. Cutout trim plates are not included.

Notes

- Tile attaches to the bottom position on stiles only.
- Specify utility support rail (TW170.) separately for each row of cutouts in utility tile.
- Specify electrical junction box attachment bracket (TW172.) for each individual cutout in utility tile.

Dimensions

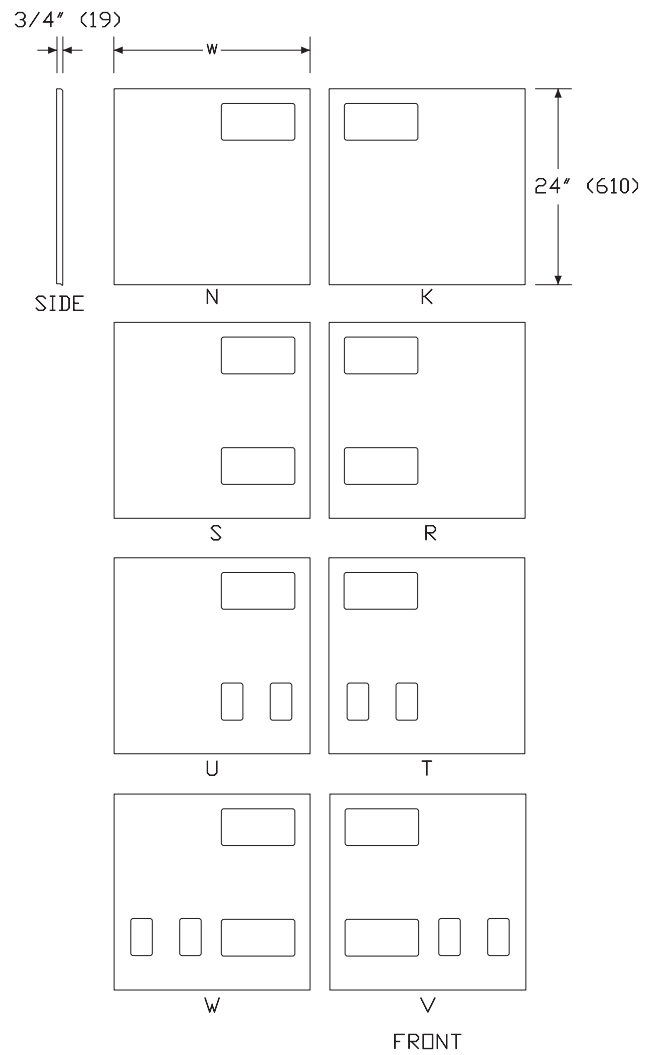

Specification Information

Step 1.

TW140.

Step 2. Width

18	18" wide
24	24" wide
36	36" wide
48	48" wide

Step 3. Configuration

K	3-gang cutout left, row 3
N	3-gang cutout right, row 3
R	3-gang cutout left, row 3, 3-gang cutout left, row 1
S	3-gang cutout right, row 3, 3-gang cutout right, row 1
T	3-gang cutout left, row 3, 2 single cutouts left, row 1
U	3-gang cutout right, row 3, 2 single cutouts right, row 1
V	3-gang cutout left, row 3, 3-gang and 2 single cutouts left, row 1
W	3-gang cutout right, row 3, 3-gang and 2 single cutouts right, row 1

Step 4. Surface Material

A	durawrap™ 3D laminate
P	3D laminate <input type="checkbox"/> A

Prices for Steps 1-4.

	A	P
TW140. 18 K	\$231	212
N	\$231	212
R	\$247	224
S	\$247	224
T	\$264	237
U	\$264	237
V	\$280	253
W	\$280	253
24 K	\$274	253
N	\$274	253
R	\$292	265
S	\$292	265
T	\$308	280
U	\$308	280
V	\$323	297
W	\$323	297

36 K	\$323	297
N	\$323	297
R	\$341	312
S	\$341	312
T	\$353	324
U	\$353	324
V	\$371	341
W	\$371	341
48 K	\$417	381
N	\$417	381
R	\$434	400
S	\$434	400
T	\$450	413
U	\$450	413
V	\$467	426
W	\$467	426

Step 5. Surface Finish

Solid-Color

For durawrap™ 3D laminate (A)

91	white (CP)	+\$0
LU	soft white	+\$0

Wood-Grain

For durawrap™ 3D laminate (A)

LBA	clear on ash (CP)	+\$10
LBB	oak on ash (CP)	+\$10
LBC	walnut on ash (CP)	+\$10
LBU	medium matte walnut (CP)	+\$10

For 3D laminate (P)

120	light maple woodgrain 3D laminate <input type="checkbox"/> A	+\$0
121	golden maple woodgrain 3D laminate <input type="checkbox"/> A	+\$0
122	brown walnut woodgrain 3D laminate <input type="checkbox"/> A	+\$0
125	light teak woodgrain 3D laminate <input type="checkbox"/> A	+\$10
126	basic white 3D laminate <input type="checkbox"/> A	+\$0

Utility Tile, Electrical, Partial-Height Upper TW141.

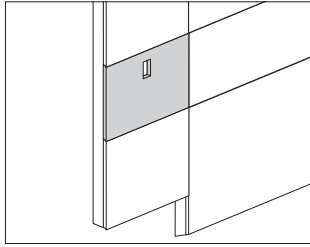

Product Information

Description

This tile attaches to 2 rail-attached stiles in the middle or upper position and has cutouts for various combinations of electrical access. It can also be used for mounting a flat panel television or monitor. The top and bottom edges are ship lapped (shingled); creating a flush joint between tiles that prevents liquids from seeping back. The tile has a 3D laminate surface. Durawrap™ 3D laminate is a 99.9% PVC-free material. Cutout trim plates are not included.

Notes

- Tile will not attach in the bottom tile position.
- When mounting a flat panel television or monitor, specify tv/monitor support bracket (TW175.) separately.
- When mounting a flat panel television or monitor, specify tile with one of the following options:
 - Single cutout center, row 3 option (A)
 - 2 single cutouts center, row 3 option (B)
 - 3 single cutouts center, row 3 option (C)
- Specify utility support rail (TW170.) separately for each row of cutouts in utility tile.
- Specify electrical junction box attachment bracket (TW172.) for each individual cutout in utility tile.

Dimensions

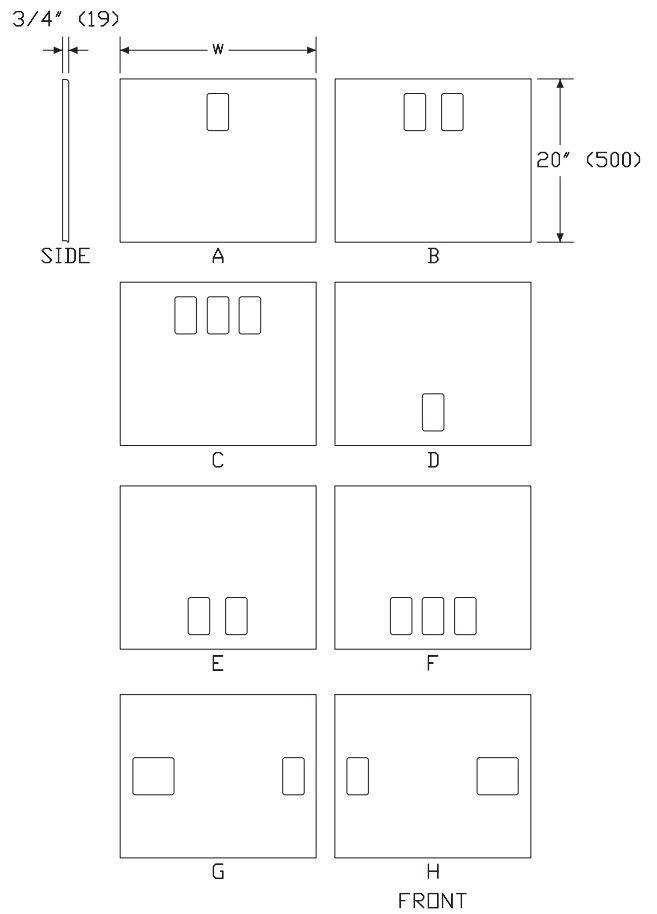

Utility Tile, Electrical, Partial-Height
Upper *continued*

Specification Information

Step 1.

TW141.

Step 2. Width

18	18" wide
24	24" wide
36	36" wide
48	48" wide

Step 3. Tile Position

M	middle tile position
T	top tile position

Step 4. Configuration

For 18" wide (18), 24" wide (24), or 36" wide (36) with middle tile position (M)

A	single cutout center, row 3
B	2 single cutouts center, row 3
C	3 single cutouts center, row 3
D	single cutout center, row 1
E	2 single cutouts center, row 1
F	3 single cutouts center, row 1

For 18" wide (18), 24" wide (24), or 36" wide (36) with top tile position (T)

A	single cutout center, row 3
B	2 single cutouts center, row 3
C	3 single cutouts center, row 3

For 48" wide (48) with middle tile position (M) or top tile position (T)

A	single cutout center, row 3
B	2 single cutouts center, row 3
C	3 single cutouts center, row 3
G	3-gang cutout left, row 2, single cutout right, row 2
H	single cutout left, row 2, 3-gang cutout right, row 2

Step 5. Surface Material

A	durawrap™ 3D laminate
P	3D laminate A

Prices for Steps 1-5.

	AA	AP	BA	BP	CA	CP
TW141. 18 M	\$210	189	225	204	240	219
T	\$210	189	225	204	240	219
24 M	\$252	229	268	243	286	260
T	\$252	229	268	243	286	260

36 M	\$315	290	330	304	346	320
T	\$315	290	330	304	346	320
48 M	\$412	376	426	391	443	405
T	\$412	376	426	391	443	405

	DA	DP	EA	EP	FA	FP
TW141. 18 M	\$273	243	291	262	304	276
24 M	\$252	229	268	243	286	260
36 M	\$315	290	330	304	346	320

	GA	GP	HA	HP
TW141. 48 M	\$426	391	426	391
T	\$426	391	426	391

Step 6. Surface Finish

Solid-Color

<i>For durawrap™ 3D laminate (A)</i>		
91	white (CP)	+\$0
LU	soft white	+\$0

Wood-Grain

<i>For durawrap™ 3D laminate (A)</i>		
LBA	clear on ash (CP)	+\$10
LBB	oak on ash (CP)	+\$10
LBC	walnut on ash (CP)	+\$10
LBU	medium matte walnut (CP)	+\$10

For 3D laminate (P)

120	light maple woodgrain 3D laminate A	+\$0
121	golden maple woodgrain 3D laminate A	+\$0
122	brown walnut woodgrain 3D laminate A	+\$0
125	light teak woodgrain 3D laminate A	+\$10
126	basic white 3D laminate A	+\$0

Utility Tile, Electrical, Full-Height
Upper

TW142.

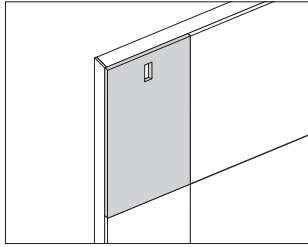

Product Information

Description

This tile attaches to 2 rail-attached stiles in the middle and upper tile positions and has cutouts for various combinations of electrical access. The top and bottom edges are ship lapped (shingled); creating a flush joint between tiles that prevents liquids from seeping back. The tile has a 3D laminate surface. Durawrap™ 3D laminate is a 99.9% PVC-free material. Cutout trim plates are not included.

Notes

- Tile will not attach in the bottom tile position.
- Specify utility support rail (TW170.) separately for each row of cutouts in utility tile.
- Specify electrical junction box attachment bracket (TW172.) for each individual cutout in utility tile.

Dimensions

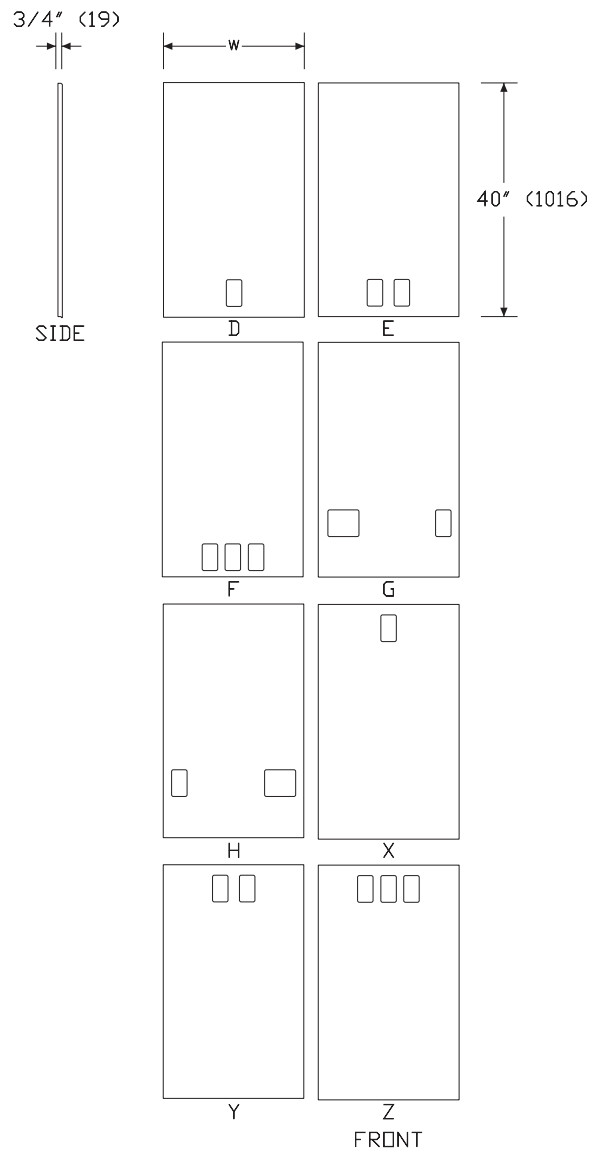

Utility Tile, Electrical, Full-Height
Upper *continued*

Specification Information

Step 1.

TW142.

Step 2. Width

18	18" wide
24	24" wide
36	36" wide
48	48" wide

Step 3. Configuration

For 18" wide (18), 24" wide (24), or 36" wide (36)

D	single cutout center, row 1
E	2 single cutouts center, row 1
F	3 single cutouts center, row 1
X	single cutout center, row 5
Y	2 single cutouts center, row 5
Z	3 single cutouts center, row 5

For 48" wide (48)

G	3-gang cutout left, row 2, single cutout right, row 2
H	single cutout left, row 2, 3-gang cutout right, row 2
X	single cutout center, row 5
Y	2 single cutouts center, row 5
Z	3 single cutouts center, row 5

Step 4. Surface Material

A	durawrap™ 3D laminate
P	3D laminate A

Prices for Steps 1-4.

	A	P
TW142. 18 D	\$342	307
E	\$358	321
F	\$325	294
X	\$342	307
Y	\$358	321
Z	\$439	393
24 D	\$412	376
E	\$426	391
F	\$443	405
X	\$412	376
Y	\$426	391
Z	\$443	405

36 D	\$523	479
E	\$536	492
F	\$555	505
X	\$523	479
Y	\$536	492
Z	\$555	505
48 G	\$624	572
H	\$624	572
X	\$607	557
Y	\$624	572
Z	\$636	586

Step 5. Surface Finish

Solid-Color

For durawrap™ 3D laminate (A)

91	white (CP)	+\$0
LU	soft white	+\$0

Wood-Grain

For durawrap™ 3D laminate (A)

LBA	clear on ash (CP)	+\$10
LBB	oak on ash (CP)	+\$10
LBC	walnut on ash (CP)	+\$10
LBU	medium matte walnut (CP)	+\$10

For 3D laminate (P)

120	light maple woodgrain 3D laminate A	+\$0
121	golden maple woodgrain 3D laminate A	+\$0
122	brown walnut woodgrain 3D laminate A	+\$0
125	light teak woodgrain 3D laminate A	+\$10
126	basic white 3D laminate A	+\$0

Nurse Call Trim Plate

TW159.

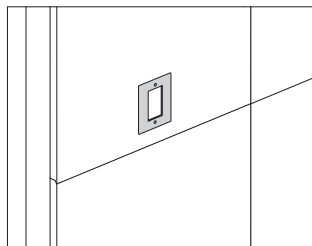

Product Information

Description

This plate attaches to a utility tile to fill the gap between the cutout and a junction box trim plate when housing a device such as 37-pin connector plug, 3- or 4-gang nurse call button, code blue button, or staff assist button. Finish is metallic silver.

Notes

Nurse call trim plate works in conjunction with field-supplied junction box trim plate.

Dimensions

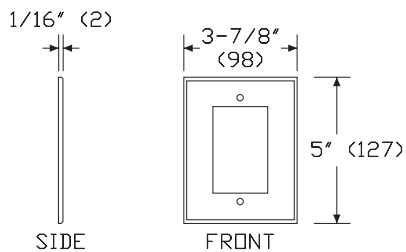

Specification Information

Step 1.

TW159.

Step 2. Type

- A single
- B double
- C triple
- D quadruple

Prices for Steps 1-2.

TW159. A	\$44
B	\$44
C	\$44
D	\$44

Utility Support Rail

TW170.

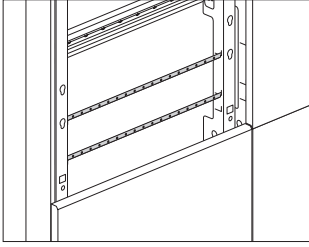

Compass™ Walls

Product Information

Description

This dual rail mounts between 2 rail-attached stiles to provide attachment for electrical junction box and gas outlet attachment brackets. Package of 2 rails supports 1 row of utilities within a utility tile. Stile attachment screws included.

Notes

Specify the following products separately:

- Electrical junction box attachment bracket (TW172.)

Dimensions

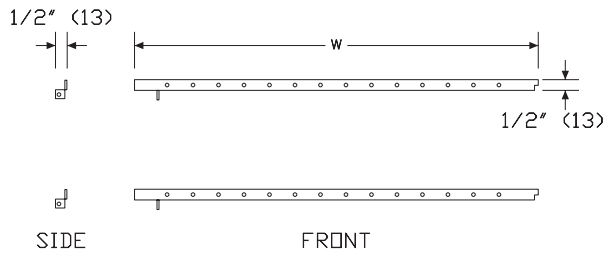

Specification Information

Step 1.

TW170.

Step 2. Width

18	18" wide
24	24" wide
36	36" wide
48	48" wide

Prices for Steps 1-2.

TW170. 18	\$27
24	\$33
36	\$46
48	\$58

Electrical Junction Box Attachment Bracket

TW172.

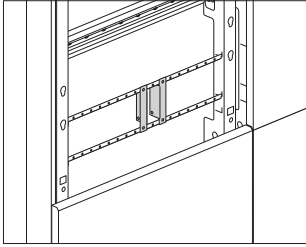

Product Information

Description

This set of L-brackets attaches to a utility support rail to support a 1-, 2-, 3-, or 4-gang electrical junction box within a utility tile. It can be specified with or without junction boxes. Rail attachment screws included.

Notes

Specify utility support rail (TW170.) separately.

Specify no junction box option (N) when junction box will be supplied in the field.

Dimensions

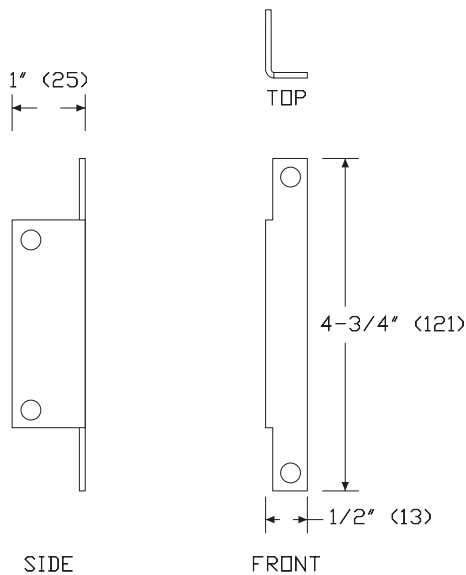

Specification Information

Step 1.

TW172.

Step 2. Quantity

- 1 pkg of 2 for 1 junction box
- 2 pkg of 12 for 6 junction boxes
- 3 pkg of 60 for 30 junction boxes

Prices for Steps 1-2.

TW172. 1	\$28
2	\$139
3	\$666

Step 3. Junction Box Type

For pkg of 2 for 1 junction box (1)

N	no junction box	+\$0
A	1-gang junction box(es)	+\$10
B	2-gang junction box(es)	+\$16
C	3-gang junction box(es)	+\$21
D	4-gang junction box(es)	+\$29

For pkg of 12 for 6 junction boxes (2)

N	no junction box	+\$0
A	1-gang junction box(es)	+\$57
B	2-gang junction box(es)	+\$95
C	3-gang junction box(es)	+\$126
D	4-gang junction box(es)	+\$170

For pkg of 60 for 30 junction boxes (3)

N	no junction box	+\$0
A	1-gang junction box(es)	+\$284
B	2-gang junction box(es)	+\$473
C	3-gang junction box(es)	+\$630
D	4-gang junction box(es)	+\$851

Electrical 4x4 Junction Box
Attachment Bracket

TW174.

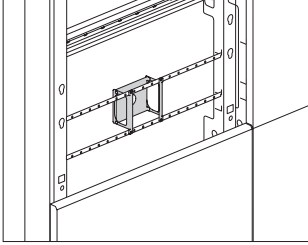

Compass™ Walls

Product Information

Description

This bracket attaches 1 4x4 junction box to a utility support rail. It can be used with 3/4" or 1" conduit alignment. Package contains 2 brackets. Rail attachment screws included.

Notes

Specify utility support rail (TW170.) separately.

Offers adjustment for 3/4" or 1" conduit alignment.

Shipped in 3/4" conduit alignment.

Dimensions

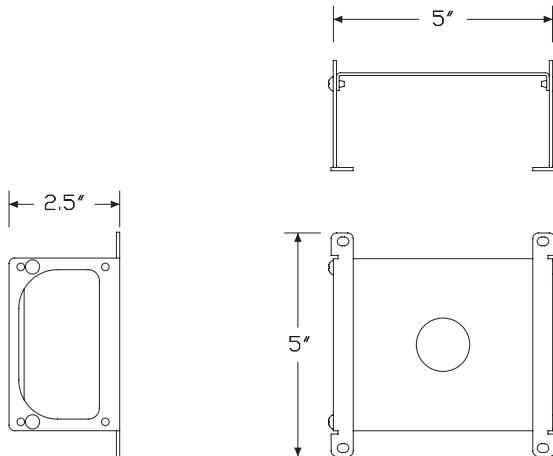

Specification Information

Step 1.

TW174.

Step 2. Quantity

1 pkg for ONE 4x4 junction box

Prices for Steps 1-2.

TW174. 1

\$103

TV/Monitor Support Bracket

TW175.

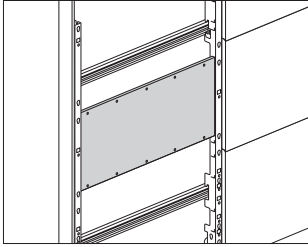

Product Information

Description

This bracket attaches between 2 rail-attached stiles to provide support when mounting a flat panel television or monitor to a utility tile.

Notes

Specify utility tile, electrical, partial-height upper (TW141.) separately.

Dimensions

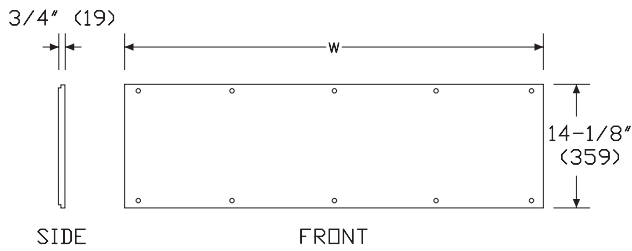

Specification Information

Step 1.

TW175.

Step 2. Width

36 36" wide

48 48" wide

Prices for Steps 1-2.

TW175. 36	\$142
48	\$167

1" Conduit Electrical Junction Box

TW176.

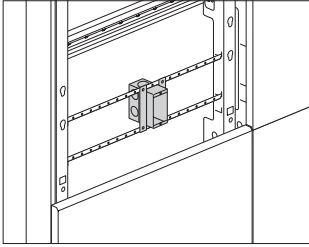

Compass™ Walls

Product Information

Description

This conduit junction box allows up to 4 Category 6a and other large volume cables to be brought in behind the compass structure without disrupting utility rails, tiles, or other components. This is designed for flexible conduit only.

Notes

Conduit access hole is either top or bottom only, not both.
Specify utility support rail (TW170.) separately.

Dimensions

Specification Information

Step 1.

TW176.

Step 2. Quantity

- 1 pkg for 1 junction box
- 2 pkg for 6 junction boxes
- 3 pkg for 30 junction boxes

Prices for Steps 1-2.

TW176. 1	\$67
2	\$360
3	\$1780

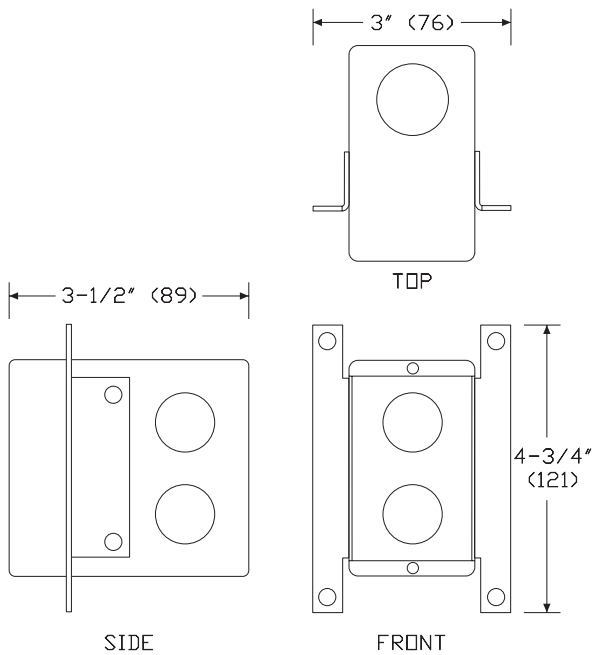

Chase

TW180.

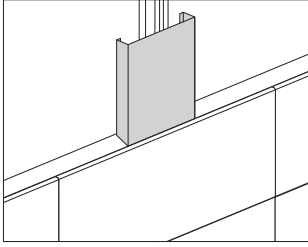

Product Information

Description

This chase attaches to an architectural wall to hide gas and electrical utilities routed from the ceiling. It can be painted in the field. Attachment hardware included.

Notes

Chase is designed to be used with 64"-high stiles in rooms with a ceiling height between 8'6" and 9' high. For other chase sizes, contact Options.
Chase accommodates up to 9 1" cables or lines with 1" space between.

Dimensions

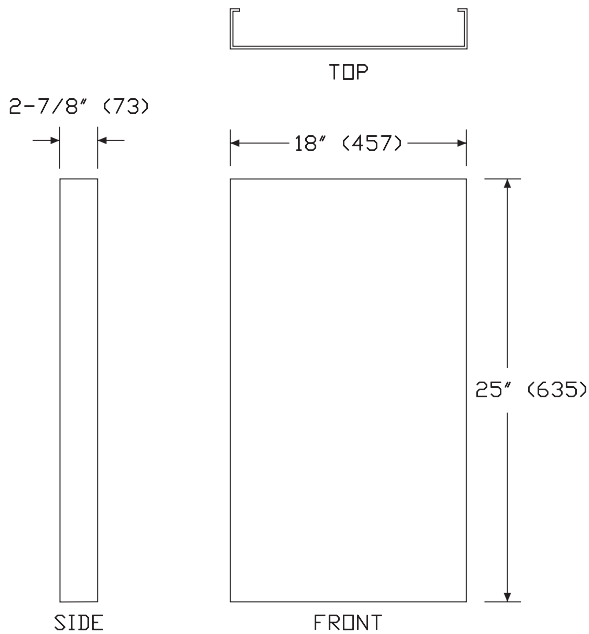

Specification Information

Step 1.

TW180.

\$263

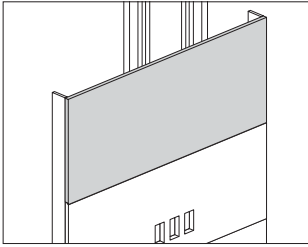

Product Information

Description
 This tile attaches to chase tile stiles to hide gas and electrical utilities routed from the ceiling. It has a 3D laminate surface. Durawrap™ 3D laminate is a 99.9% PVC-free material.

Notes

Specify stile, chase tile (TW114.) separately.
 Chase tile is designed to be used with 64"-high stiles in rooms with a ceiling height between 8'6" and 9' high. For other chase sizes, contact Options.

Dimensions

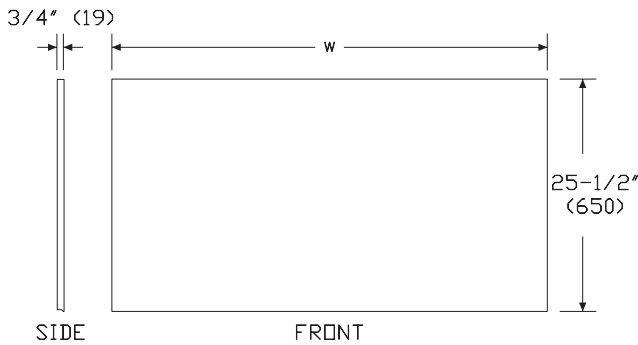

Specification Information

Step 1.

TW182.

Step 2. Width

- 24 24" wide
- 36 36" wide
- 48 48" wide

Step 3. Surface Material

- A durawrap™ 3D laminate
- P 3D laminate

Prices for Steps 1-3.

	A	P
TW182. 24	\$429	392
36	\$469	426
48	\$492	448

Step 4. Surface Finish

Solid-Color

For durawrap™ 3D laminate (A)

91	white (CP)	+\$0
LU	soft white	+\$0

Wood-Grain

For durawrap™ 3D laminate (A)

LBA	clear on ash (CP)	+\$10
LBB	oak on ash (CP)	+\$10
LBC	walnut on ash (CP)	+\$10
LBU	medium matte walnut (CP)	+\$10

For 3D laminate (P)

120	light maple woodgrain 3D laminate <input type="checkbox"/>	+\$0
121	golden maple woodgrain 3D laminate <input type="checkbox"/>	+\$0
122	brown walnut woodgrain 3D laminate <input type="checkbox"/>	+\$0
125	light teak woodgrain 3D laminate <input type="checkbox"/>	+\$10
126	basic white 3D laminate <input type="checkbox"/>	+\$0

Work Surface

TW210.
TW211.

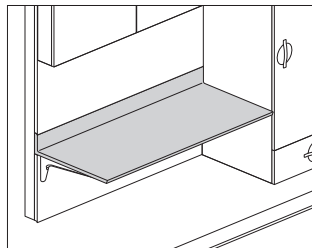

Product Information

Description

This work surface attaches to a work surface tile and is available in 3D laminate or Corian®. Durawrap™ 3D laminate is a 99.9% PVC-free material. It can be specified with an integrated backsplash or without and can mount on cantilevers, a drawer module, or a combination of both.

Notes

A surface up to 48" wide requires 2 supports. 54" wide and wider surfaces require 3 supports.

Specify the following products separately:

- Cantilever (TW219.)
- Drawer Module (TW310.)
- Work surface tile (TW124.)

Dimensions

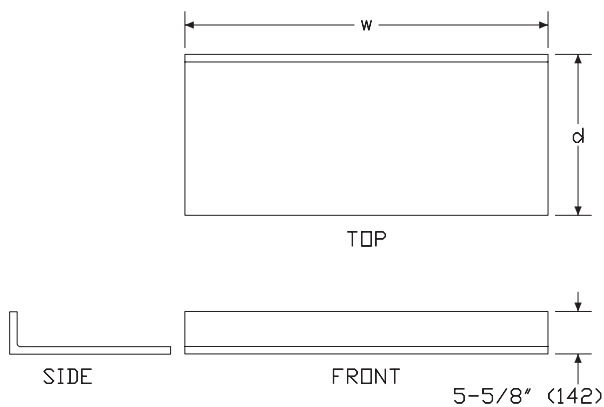

Specification Information

Step 1.

TW21

Step 2. Backsplash

- 0. with backsplash
- 1. without backsplash

Step 3. Depth

- 13 13" deep
- 21 21" deep

Step 4. Width

- 12 12" wide
- 18 18" wide
- 24 24" wide
- 30 30" wide
- 36 36" wide
- 42 42" wide
- 48 48" wide
- 54 54" wide
- 60 60" wide
- 66 66" wide
- 72 72" wide

Step 5. Surface Material

For with backsplash (0.)

- A durawrap™ 3D laminate
- K corian

For without backsplash (1.)

- A durawrap™ 3D laminate
- K corian
- P 3D laminate A

Prices for Steps 1-5.					
		A	K	P	
TW210. 13	12	\$612	673	—	
	18	\$676	741	—	
	24	\$741	810	—	
	30	\$828	944	—	
	36	\$916	1130	—	
	42	\$1045	1285	—	
	48	\$1172	1443	—	
	54	\$1294	1595	—	
	60	\$1413	1755	—	
	66	\$1534	1911	—	
	72	\$1656	2066	—	
	21	12	\$713	775	—
	18		\$825	907	—
	24		\$932	1036	—
	30		\$1061	1297	—
	36		\$1188	1560	—
	42		\$1494	1722	—
	48		\$1793	1881	—
	54		\$1837	2150	—
60		\$1881	2416	—	
66		\$1922	2670	—	
72		\$1967	2931	—	
		A	K	P	
TW211. 13	12	\$282	557	260	
	18	\$292	583	268	
	24	\$302	607	276	
	30	\$405	638	370	
	36	\$422	835	385	
	42	\$455	941	418	
	48	\$494	1048	449	
	54	\$527	1158	479	
	60	\$559	1267	510	
	66	\$605	1385	553	
	72	\$648	1497	593	

21	12	\$320	592	290
18		\$346	705	317
24		\$373	820	342
30		\$443	1052	404
36		\$494	1241	458
42		\$527	1365	484
48		\$559	1489	510
54		\$597	1699	543
60		\$630	1910	576
66		\$675	2122	616
72		\$718	2336	656

Step 6. Surface Finish

Solid-Color

For without backsplash (1.) with durawrap™ 3D laminate (A)

91	white (CP)			+\$0
LU	soft white			+\$0

Wood-Grain

For without backsplash (1.) with durawrap™ 3D laminate (A)

LBA	clear on ash (CP)			+\$10
LBB	oak on ash (CP)			+\$10
LBC	walnut on ash (CP)			+\$10
LBU	medium matte walnut (CP)			+\$10

Solid-Color

For with backsplash (0.) with durawrap™ 3D laminate (A)

91	white (CP)			+\$0
LU	soft white			+\$0

For corian (K)

CQ	glacier white			+\$0
QB	bisque			+\$0
58	cameo white			+\$0
1S	savannah			+\$50
1U	sahara			+\$50
4I	sandstone			+\$50
IQ	aurora			+\$50
OQ	silt			+\$50
ANC	antarctica			+\$50
SVG	silver gray A			+\$50
CRT	concrete			+\$120
DVC	dove			+\$120

For without backsplash (1.) with 3D laminate (P)

126	basic white 3D laminate A			+\$0
-----	---	--	--	------

Cantilever

TW219.

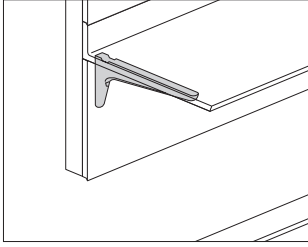

Product Information

Description

This single cantilever supports a work surface at either end, or in the middle. Finish is metallic silver.

Notes

Specify the following products separately:

- Work surface (TW210.)
- Work surface tile (TW124.)

Dimensions

Specification Information

Step 1.

TW219.

Step 2. Depth

- 13** for 13" deep work surface
- 21** for 21" deep work surface

Prices for Steps 1-2.

TW219. 13	\$91
21	\$112

Compass™ Surfaces

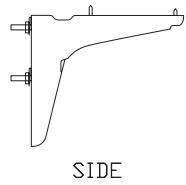
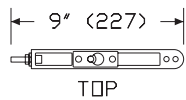
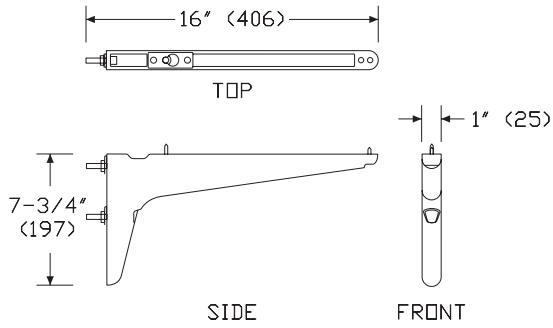

Rotating Work Surface Support
Bracket

TW229.

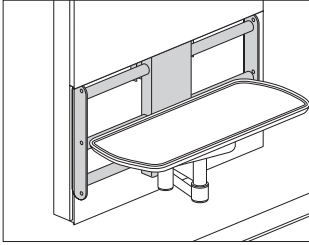

Compass™ Surfaces

Product Information

Description

This support bracket attaches between 2 rail-attached stiles behind a rotating work surface tile to support a rotating work surface.

Notes

Specify the following products separately:

- Rotating work surface arm (TW221.)
- Rotating work surface top (TW222.)
- Rotating work surface tile (TW126.)

Dimensions

Specification Information

Step 1.

TW229.36

\$266

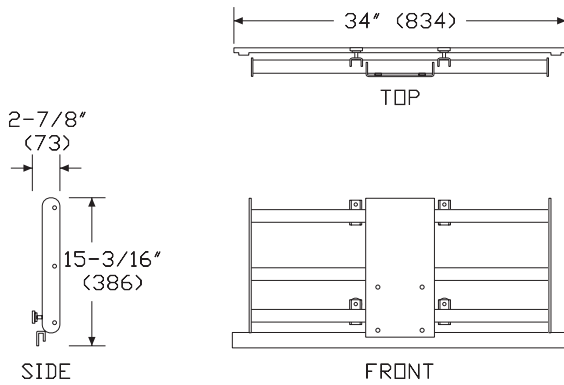

Rotating Work Surface Arm

TW221.

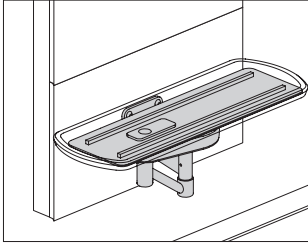

Product Information

Description

This arm attaches to a rotating work surface tile and accepts the rotating work surface top. The rotating arm finish is metallic silver.

Notes

Surface can be used in seated- or standing-height applications.

Specify the following products separately:

- Rotating work surface support bracket (TW229.)
- Rotating work surface tile (TW126.)
- Rotating work surface top (TW222.)

Dimensions

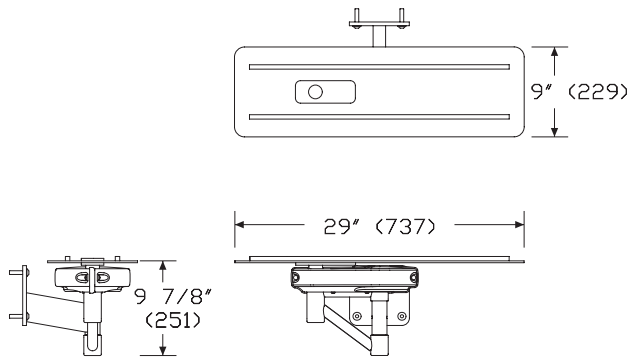

Specification Information

Step 1.

TW221.

\$2454

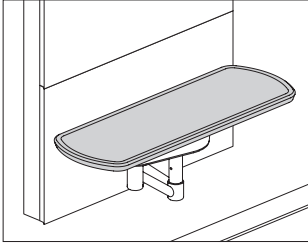

Product Information

Description

This extendable surface attaches to a rotating work surface arm and has a 3D laminate or Corian® finish. Durawrap™ 3D laminate is a 99.9% PVC-free material.

Notes

Surface can be used in seated- or standing-height applications.

Specify the following products separately:

- Rotating work surface support bracket (TW229.)
- Rotating work surface tile (TW126.)
- Rotating work surface arm (TW221.)

Dimensions

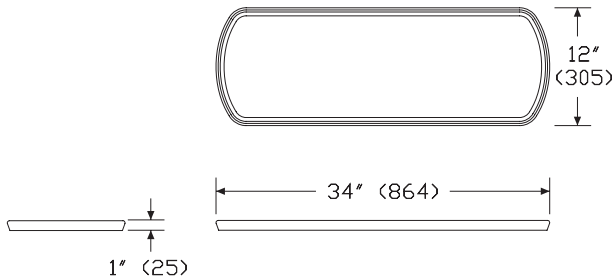

Specification Information

Step 1.

TW222.

Step 2. Surface Material

- A** durawrap™ 3D laminate
- K** corian
- P** 3D laminate A

Prices for Steps 1-2.

TW222. A	\$424
K	\$967
P	\$388

Step 3. Surface Finish

Solid-Color

For durawrap™ 3D laminate (A)

91 white (CP)	+\$0
LU soft white	+\$0

Wood-Grain

For durawrap™ 3D laminate (A)

LBA clear on ash (CP)	+\$10
LBB oak on ash (CP)	+\$10
LBC walnut on ash (CP)	+\$10
LBU medium matte walnut (CP)	+\$10

For corian (K)

58 cameo white	+\$0
CQ glacier white	+\$0
QB bisque	+\$0
1S savannah	+\$50
1U sahara	+\$50
4I sandstone	+\$50
ANC antarctica	+\$50
IQ aurora	+\$50
OQ silt	+\$50
SVG silver gray	+\$50
CRT concrete	+\$120
DVC dove	+\$120

Rotating Work Surface Top *continued*

For 3D laminate (P)

120	light maple woodgrain 3D laminate <input type="checkbox"/> A	+\$0
121	golden maple woodgrain 3D laminate <input type="checkbox"/> A	+\$0
122	brown walnut woodgrain 3D laminate <input type="checkbox"/> A	+\$0
125	light teak woodgrain 3D laminate <input type="checkbox"/> A	+\$10
126	basic white 3D laminate <input type="checkbox"/> A	+\$0

Sink, 13" Deep

TW230.

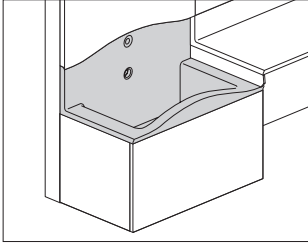

Compass™ Surfaces

Product Information

Description

This Corian® sink attaches to 2 rail-attached stiles and has an integrated backsplash. The backsplash is curved and can be specified with holes to accept a faucet (TW239.). Drain assembly not included.

Notes

Sink does not have an overflow hole.

Specify the following products separately:

- Above sink tile (TW128.)
- Faucet (TW239.)
- Sink enclosure (TW232.)

Dimensions

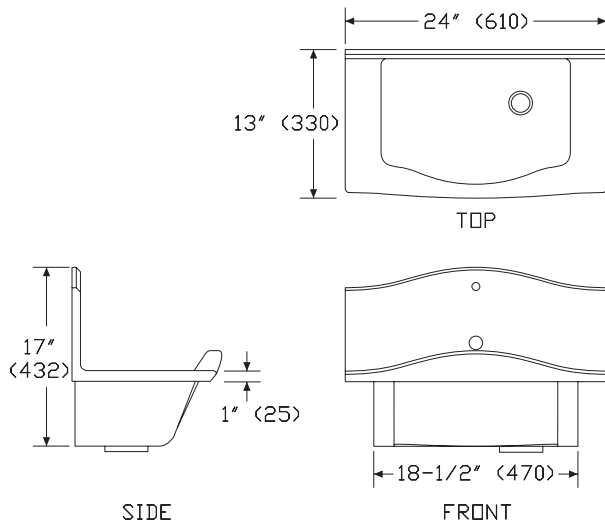

Specification Information

Step 1.

TW230.1324 A

Step 2. Type

H faucet holes A

N no faucet holes A

Prices for Steps 1-2.

TW230.1324	H	\$3525
	N	\$3490

Step 3. Surface Finish

58	cameo white <input type="checkbox"/> A	+\$0
CQ	glacier white <input type="checkbox"/> A	+\$0
QB	bisque <input type="checkbox"/> A	+\$0
1S	savannah <input type="checkbox"/> A	+\$180
1U	sahara <input type="checkbox"/> A	+\$180
4I	sandstone <input type="checkbox"/> A	+\$180
ANC	antarctica <input type="checkbox"/> A	+\$180
IQ	aurora <input type="checkbox"/> A	+\$180
OQ	silt <input type="checkbox"/> A	+\$180
SVG	silver gray <input type="checkbox"/> A	+\$180
CRT	concrete <input type="checkbox"/> A	+\$320
DVC	dove <input type="checkbox"/> A	+\$320

Sink, 21" Deep

TW231.

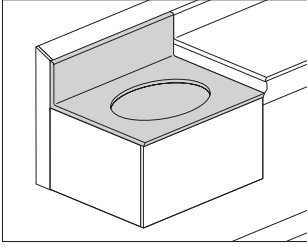

Product Information

Description

This Corian® sink attaches to 2 rail-attached stiles and has an integrated backsplash.

Notes

Specify sink enclosure (TW232.) separately.

Sink does not accept faucet (TW239.). Faucet must be field-supplied.

Dimensions

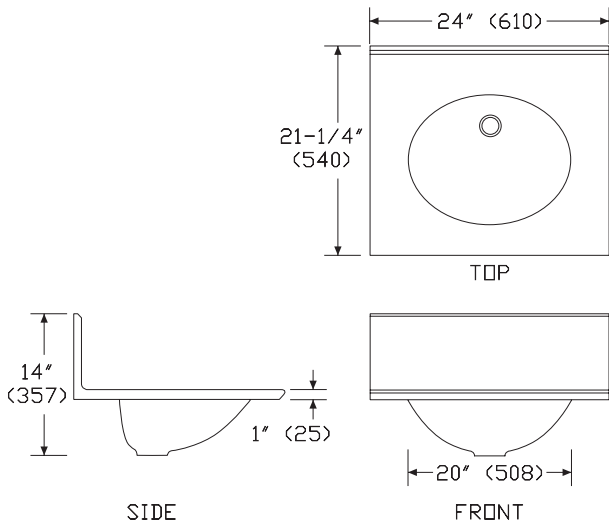

Specification Information

Step 1.

TW231.2124N \$1931

Step 2. Sink Top Finish

ANC	antarctica <input type="checkbox"/>	+\$60
CRT	concrete <input type="checkbox"/>	+\$140
DVC	dove <input type="checkbox"/>	+\$140
CQ	glacier white <input type="checkbox"/>	+\$0
QB	bisque <input type="checkbox"/>	+\$0
1S	savannah <input type="checkbox"/>	+\$60
1U	sahara <input type="checkbox"/>	+\$60
4I	sandstone <input type="checkbox"/>	+\$60
58	cameo white <input type="checkbox"/>	+\$0
IQ	aurora <input type="checkbox"/>	+\$60
OQ	silt <input type="checkbox"/>	+\$60

Step 3. Sink Bowl Finish

CQ	glacier white <input type="checkbox"/>	+\$0
QB	bisque <input type="checkbox"/>	+\$0
58	cameo white <input type="checkbox"/>	+\$0

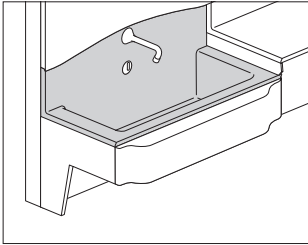

Product Information

Description

This ADA designed Corian sink attaches to 2 rail-attached stiles and has an integrated backsplash. The backslash can be specified with holes to accept a faucet (TW239). Drain assembly not included.

Notes

Sink does not have an overflow hole.
 Specify the following products separately:
 • Above sink tile (TW129)
 • Faucet (TW239)

Dimensions

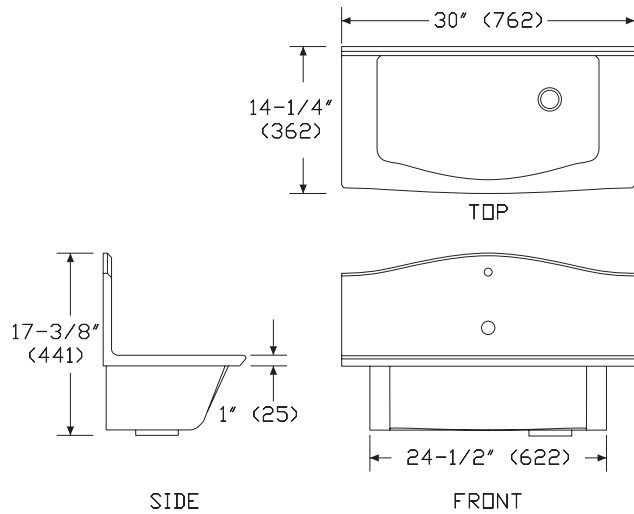

Specification Information

Step 1.

TW235.1330 A

Step 2. Type

H faucet holes A

N no faucet holes A

Prices for Steps 1-2.

TW235.1330	H	\$4392
	N	\$4078

Step 3. Surface Finish

58	cameo white <input type="checkbox"/> A	+\$0
CQ	glacier white <input type="checkbox"/> A	+\$0
QB	bisque <input type="checkbox"/> A	+\$0
1S	savannah <input type="checkbox"/> A	+\$210
1U	sahara <input type="checkbox"/> A	+\$210
4I	sandstone <input type="checkbox"/> A	+\$210
ANC	antarctica <input type="checkbox"/> A	+\$210
IQ	aurora <input type="checkbox"/> A	+\$210
OQ	silt <input type="checkbox"/> A	+\$210
SVG	silver gray <input type="checkbox"/> A	+\$210
CRT	concrete <input type="checkbox"/> A	+\$280
DVC	dove <input type="checkbox"/> A	+\$280

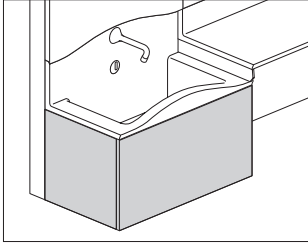

Product Information

Description

This enclosure attaches to a 13"- or 21"-deep sink to finish the area below the sink top and hide the plumbing. It has a 3D laminate surface. Durawrap™ 3D laminate is a 99.9% PVC-free material. Attachment hardware included.

Dimensions

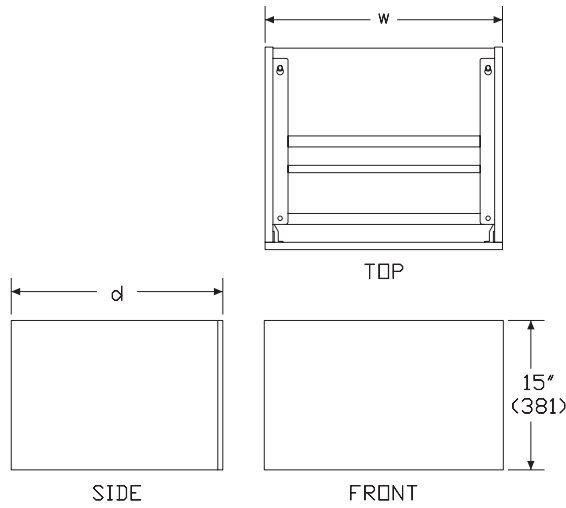

Specification Information

Step 1.

TW232.

Step 2. Depth

- 13 13" deep
- 21 21" deep

Step 3. Width

For 13" deep (13)

- 24 24" wide

For 21" deep (21)

- 24 24" wide

Step 4. Surface Material

- A durawrap™ 3D laminate
- P 3D laminate A

Prices for Steps 1-4.

		A	P
TW232. 13 24		\$828	756
	21 24	\$1164	1065

Step 5. Side Finish

Solid-Color

For durawrap™ 3D laminate (A)

- 91 white (CP) +\$0
- LU soft white +\$0

Wood-Grain

For durawrap™ 3D laminate (A)

- LBA clear on ash (CP) +\$10
- LBB oak on ash (CP) +\$10
- LBC walnut on ash (CP) +\$10
- LBU medium matte walnut (CP) +\$10

For 3D laminate (P)

- 120 light maple woodgrain 3D laminate A +\$0
- 121 golden maple woodgrain 3D laminate A +\$0
- 122 brown walnut woodgrain 3D laminate A +\$0
- 125 light teak woodgrain 3D laminate A +\$10
- 126 basic white 3D laminate A +\$0

Sink Enclosure *continued*

Compass™ Surfaces

Step 6. Front Finish

Solid-Color

For durawrap™ 3D laminate (A)

91	white (CP)	+\$0
LU	soft white	+\$0

Wood-Grain

For durawrap™ 3D laminate (A)

LBA	clear on ash (CP)	+\$10
LBB	oak on ash (CP)	+\$10
LBC	walnut on ash (CP)	+\$10
LBU	medium matte walnut (CP)	+\$10

For 3D laminate (P)

120	light maple woodgrain 3D laminate <input type="checkbox"/> A	+\$0
121	golden maple woodgrain 3D laminate <input type="checkbox"/> A	+\$0
122	brown walnut woodgrain 3D laminate <input type="checkbox"/> A	+\$0
125	light teak woodgrain 3D laminate <input type="checkbox"/> A	+\$10
126	basic white 3D laminate <input type="checkbox"/> A	+\$0

Sink Enclosure, ADA-Compliant Sink TW233.

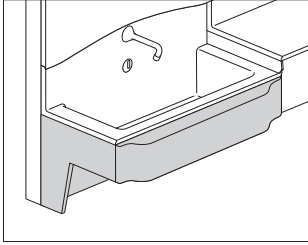

Product Information

Description

This enclosure attaches to an ADA sink to finish the area below the sink top and hide the plumbing. It has a 3D laminate surface. Durawrap™ 3D laminate is a 99.9% PVC-free material. Attachment hardware included.

Dimensions

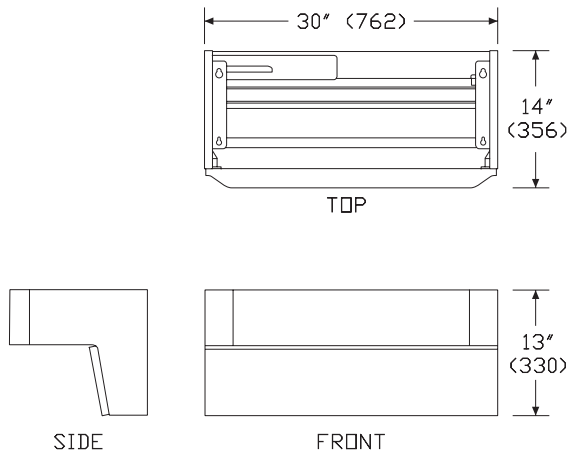

Specification Information

Step 1.

TW233.1330

Step 2. Surface Material

- A** durawrap™ 3D laminate
- P** 3D laminate A

Prices for Steps 1-2.

TW233.1330	A	\$1062
	P	\$968

Step 3. Side Finish

Solid-Color

For durawrap™ 3D laminate (A)

91	white (CP)	+\$0
LU	soft white	+\$0

Wood-Grain

For durawrap™ 3D laminate (A)

LBA	clear on ash (CP)	+\$10
LBB	oak on ash (CP)	+\$10
LBC	walnut on ash (CP)	+\$10
LBU	medium matte walnut (CP)	+\$10

For 3D laminate (P)

120	light maple woodgrain 3D laminate A	+\$0
121	golden maple woodgrain 3D laminate A	+\$0
122	brown walnut woodgrain 3D laminate A	+\$0
125	light teak woodgrain 3D laminate A	+\$10
126	basic white 3D laminate A	+\$0

Step 4. Front Finish

Solid-Color

For durawrap™ 3D laminate (A)

91	white (CP)	+\$0
LU	soft white	+\$0

Wood-Grain

For durawrap™ 3D laminate (A)

LBA	clear on ash (CP)	+\$10
LBB	oak on ash (CP)	+\$10
LBC	walnut on ash (CP)	+\$10
LBU	medium matte walnut (CP)	+\$10

Sink Enclosure, ADA-Compliant Sink

continued

Compass™ Surfaces

For 3D laminate (P)

120	light maple woodgrain 3D laminate <input type="checkbox"/> A	+\$0
121	golden maple woodgrain 3D laminate <input type="checkbox"/> A	+\$0
122	brown walnut woodgrain 3D laminate <input type="checkbox"/> A	+\$0
125	light teak woodgrain 3D laminate <input type="checkbox"/> A	+\$15
126	basic white 3D laminate <input type="checkbox"/> A	+\$0

Faucet

TW239.

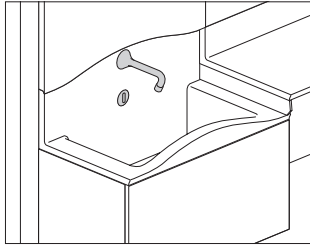

Product Information

Description

This faucet is designed to work with a 13" deep sink and includes a hands-free sensor. Supply-line hoses, shutoff valves, mixing valve and drain hardware not included.

Notes

AC powered faucet sensor option (A) requires an electrical outlet to plug into. It is recommended that the outlet be located to fit inside the sink surround. Battery powered faucet sensor option (C) uses 4 AA batteries (included).

Dimensions

Specification Information

Step 1.

TW239.

Step 2. Faucet Sensor Type

- A** ac powered faucet sensor
- C** battery powered faucet sensor

Prices for Steps 1-2.

TW239. A	\$1633
C	\$1524

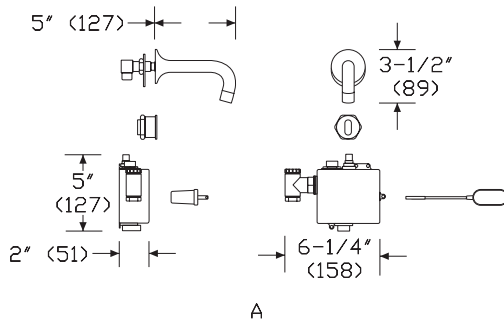

A

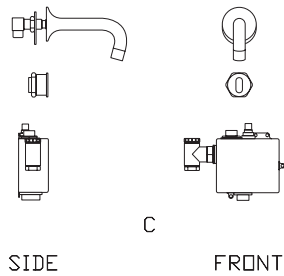

C

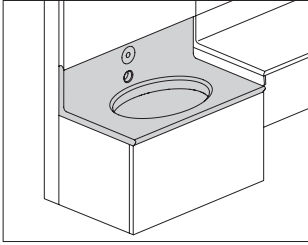

Product Information

Description

This Corian® sink attaches to 2 rail-attached stiles and has an integrated backsplash. It can be specified with holes to accept a faucet. Drain assembly not included.

Notes

Sink bowl is a Corian glacier white finish.

Sink does not have an overflow hole.

Specify the following products separately:

- Faucet (TW239.)
- Sink enclosure (TW232.)

Dimensions

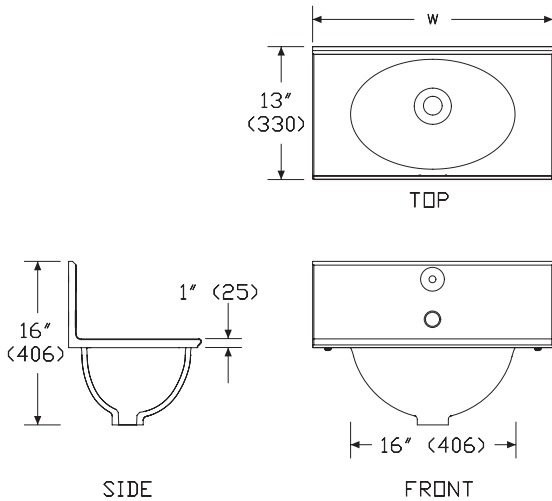

Specification Information

Step 1.

TW234.13 A

Step 2. Width

24 24" wide A

Step 3. Type

H faucet holes A

N no faucet holes A

Prices for Steps 1-3.

		H	N
TW234.13	24	\$1967	1895

Step 4. Sink Top Finish

58	cameo white <input type="checkbox"/> A	+\$0
CQ	glacier white <input type="checkbox"/> A	+\$0
QB	bisque <input type="checkbox"/> A	+\$0
1S	savannah <input type="checkbox"/> A	+\$60
1U	sahara <input type="checkbox"/> A	+\$60
4I	sandstone <input type="checkbox"/> A	+\$60
ANC	antarctica <input type="checkbox"/> A	+\$60
IQ	aurora <input type="checkbox"/> A	+\$60
OQ	silt <input type="checkbox"/> A	+\$60
SVG	silver gray <input type="checkbox"/> A	+\$60
CRT	concrete <input type="checkbox"/> A	+\$140
DVC	dove <input type="checkbox"/> A	+\$140

Sidesplash

TW242.

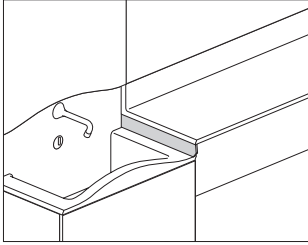

Product Information

Description

This sidesplash attaches to the left or right side of a 13" or 21"-deep sink top to fill the gap between the edge of the sink and an adjacent standing-height work surface. Finish is Corian®. Attachment hardware included.

Notes

It is recommended to caulk the seam between the sidesplash and surface.

Dimensions

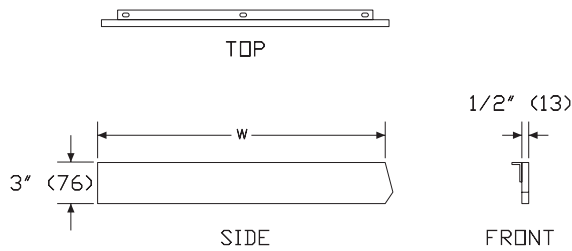

Specification Information

Step 1.

TW242. [A]

Step 2. Width

13 13" wide [A]

21 21" wide [A]

Step 3. Orientation

L left [A]

R right [A]

Step 4. Attachment Method

A durawrap™ 3D laminate or 3D laminate work surface attachment [A]

B corian work surface attachment [A]

Prices for Steps 1-4.

	A	B
TW242. 13 L	\$271	265
R	\$271	265
21 L	\$290	285
R	\$290	285

Step 5. Surface Finish

58 cameo white [A]		+\$0
CQ glacier white [A]		+\$0
QB bisque [A]		+\$0
1S savannah [A]		+\$50
1U sahara [A]		+\$50
4I sandstone [A]		+\$50
ANC antarctica [A]		+\$50
IQ aurora [A]		+\$50
OQ silt [A]		+\$50
SVG silver gray [A]		+\$50
CRT concrete [A]		+\$75
DVC dove [A]		+\$75

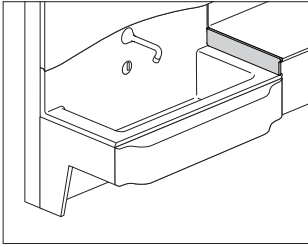

Product Information

Description

This sidesplash attaches to the left or right side of a 13"-deep ADA compliant sink top to fill the gap between the edge of the sink and an adjacent standing-height work surface. Finish is Corian®. Attachment hardware included.

Notes

It is recommended to caulk the seam between the sidesplash and surface.

Dimensions

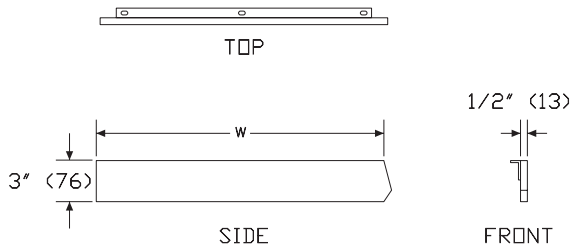

Specification Information

Step 1.

TW243. A

Step 2. Width

13 13" wide A

Step 3. Orientation

L left A

R right A

Step 4. Attachment Method

A durawrap™ 3D laminate or 3D laminate work surface attachment A

B corian work surface attachment A

Prices for Steps 1-4.

	A	B
TW243. 13 L	\$294	288
R	\$294	288

Step 5. Surface Finish

58	cameo white <input type="checkbox"/> A	+\$0
CQ	glacier white <input type="checkbox"/> A	+\$0
QB	bisque <input type="checkbox"/> A	+\$0
1S	savannah <input type="checkbox"/> A	+\$50
1U	sahara <input type="checkbox"/> A	+\$50
4I	sandstone <input type="checkbox"/> A	+\$50
ANC	antarctica <input type="checkbox"/> A	+\$50
IQ	aurora <input type="checkbox"/> A	+\$50
OQ	silt <input type="checkbox"/> A	+\$50
SVG	silver gray <input type="checkbox"/> A	+\$50
CRT	concrete <input type="checkbox"/> A	+\$75
DVC	dove <input type="checkbox"/> A	+\$75

Wardrobe Cabinet

TW300.

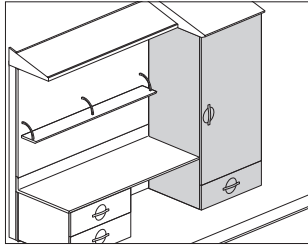

Product Information

Description

This non-locking cabinet attaches to 2 64"-high rail-attached stiles to provide storage for patient clothing and personal items. It has an upper interior shelf and a rod for hangers, and is available with a lower drawer. Top of cabinet requires a sloped cabinet top close-out, specified separately. The outside of the cabinet and the door/drawer fronts have 3D laminate surfaces. Durawrap™ 3D laminate is a 99.9% PVC-free material.

Notes

Drawer option (D) has full-extension ball-bearing slides.
 No drawer option (N) has a full-height door with an additional lower shelf.
 For bow pull option (C), pull finish is matte stainless. For arc pull option (D), pull finish is brushed nickel.
 Specify close-out, sloped cabinet top (TW406.) separately.
 Drawer liner will be installed if selected on unit.

Dimensions

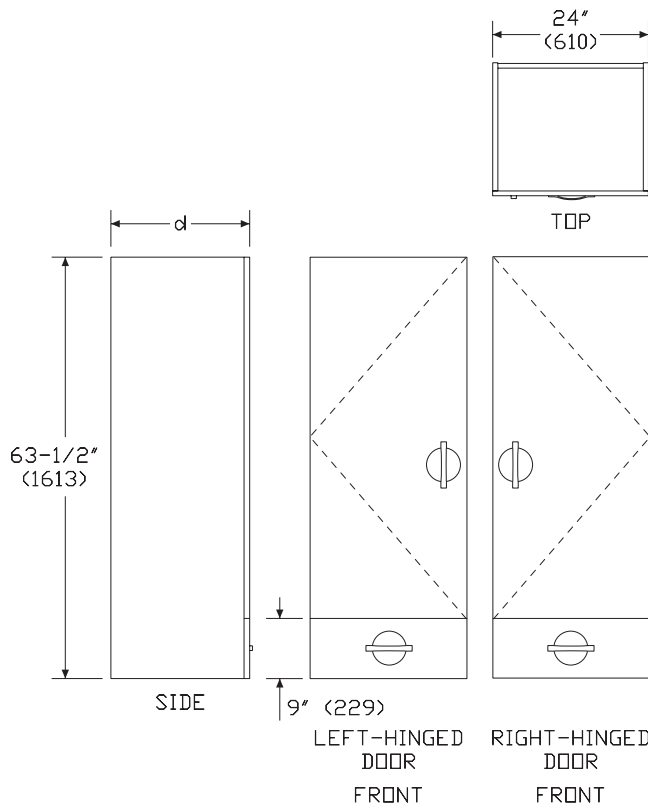

Specification Information

Step 1.

TW300.

Step 2. Depth

13 13" deep
 21 21" deep

Step 3. Drawer Option

D drawer with fixed upper interior shelf and rod
 N no drawer with fixed upper and lower interior shelf and rod

Step 4. Door Hinge Location

L left-hinged door
 R right-hinged door

Step 5. Pull Type

B flex pull
 C bow pull
 D arc pull
 N no pull

Step 6. Surface Material

A durawrap™ 3D laminate
 P 3D laminate [A]

Prices for Steps 1-6.

		LBA	LBP	LCA	LCP	LDA	LDP
TW300. 13	D	\$2484	2268	2465	2250	2465	2250
	N	\$2225	2031	2216	2023	2216	2023
	21	\$2876	2623	2857	2606	2857	2606
	N	\$2465	2250	2454	2238	2454	2238
		LNA	LNP	RBA	RBP	RCA	RCP
TW300. 13	D	\$2442	2228	2484	2268	2465	2250
	N	\$2204	2012	2225	2031	2216	2023
	21	\$2837	2586	2876	2623	2857	2606
	N	\$2442	2228	2465	2250	2454	2238
			RDA	RDP	RNA	RNP	
TW300. 13	D		\$2465	2250	2442	2228	
	N		\$2216	2023	2204	2012	
	21		\$2857	2606	2837	2586	
	N		\$2454	2238	2442	2228	

Wardrobe Cabinet *continued*

Compass™ Storage

Step 7. Top/Side Finish

Solid-Color

For durawrap™ 3D laminate (A)

91	white (CP)	+\$0
LU	soft white	+\$0

Wood-Grain

For durawrap™ 3D laminate (A)

LBA	clear on ash (CP)	+\$10
LBB	oak on ash (CP)	+\$10
LBC	walnut on ash (CP)	+\$10
LBU	medium matte walnut (CP)	+\$10

For 3D laminate (P)

120	light maple woodgrain 3D laminate A	+\$0
121	golden maple woodgrain 3D laminate A	+\$0
122	brown walnut woodgrain 3D laminate A	+\$0
125	light teak woodgrain 3D laminate A	+\$25
126	basic white 3D laminate A	+\$0

Step 8. Front Finish

Solid-Color

For durawrap™ 3D laminate (A)

91	white (CP)	+\$0
LU	soft white	+\$0

Wood-Grain

For durawrap™ 3D laminate (A)

LBA	clear on ash (CP)	+\$10
LBB	oak on ash (CP)	+\$10
LBC	walnut on ash (CP)	+\$10
LBU	medium matte walnut (CP)	+\$10

For 3D laminate (P)

120	light maple woodgrain 3D laminate A	+\$0
121	golden maple woodgrain 3D laminate A	+\$0
122	brown walnut woodgrain 3D laminate A	+\$0
125	light teak woodgrain 3D laminate A	+\$25
126	basic white 3D laminate A	+\$0

Step 9. Pull Finish

For flex pull (B)

63	fog	+\$0
-----------	-----	------

Step 10. Drawer Liner

For drawer with fixed upper interior shelf and rod (D)

NDL	no drawer liner	+\$0
DRL	drawer liner	+\$65

Full Height Storage Cabinet

TW302.

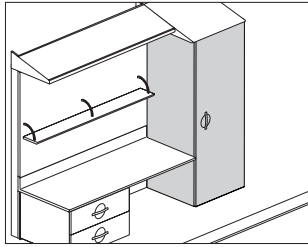

Product Information

Description

This storage cabinet attaches to 2 64"-high rail-attached stiles to provide storage for supplies. It comes with 4 adjustable shelves or 2 adjustable shelves and a Co/Struc® adapter that mounts inside the cabinet. The adapter has 9 slots at 3" intervals to support Co/Struc storage components and accessories. The adapter allows the interior flexibility of Co/Struc storage products with the aesthetic of Compass™. If top of cabinet requires a sloped cabinet top close-out, specify separately. The outside of the cabinet and the door front have 3D laminate surfaces. Durawrap™ 3D laminate is a 99.9% PVC-free material.

Notes

For Co/Struc adapter option (C), order storage components separately:

- A-, B-, or C-size drawer (CO207, CO208, or CO209)
- C tray/shelf (CO203)
- C wire shelf (CO252)

For bow pull option (C), pull finish is matte stainless. For arc pull option (D), pull finish is brushed nickel.

Specify close-out, sloped cabinet top (TW406.) separately.

Dimensions

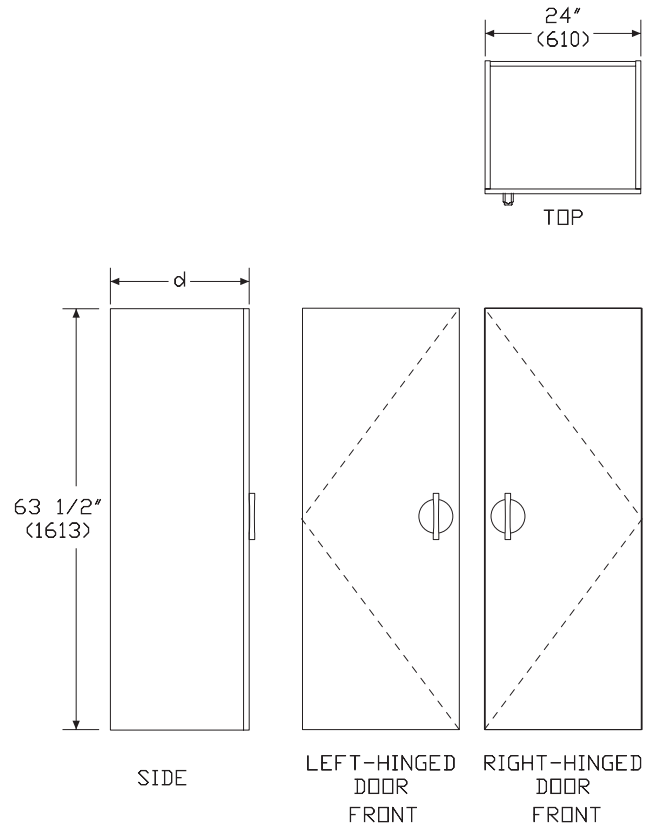

Compass™ Storage

Full Height Storage Cabinet *continued*

Compass™ Storage

Specification Information

Step 1.

TW302.

Step 2. Depth

13	13" deep
21	21" deep

Step 3. Storage Options

For 13" deep (13)

A	4 adjustable shelves
---	----------------------

For 21" deep (21)

A	4 adjustable shelves
C	2 adjustable shelves, Co/Struc adaptor included

Step 4. Door Hinge Location

L	left-hinged door
R	right-hinged door

Step 5. Pull Type

B	flex pull
C	bow pull
D	arc pull
N	no pull

Step 6. Storage Locks

L	keyless lock
N	no lock

Step 7. Surface Material

A	durawrap™ 3D laminate
P	3D laminate

Prices for Steps 1-7.

	LBLA	LBLP	LBNA	LBNP	LCLA	LCLP
TW302. 13 A	\$3445	3199	3081	2840	3411	3169
21 A	\$4171	3903	3807	3539	4130	3865
C	\$4354	4085	3988	3719	4310	4044

	LCNA	LCNP	LDLA	LDLP	LDNA	LDNP
TW302. 13 A	\$3051	2809	3411	3169	3051	2809
21 A	\$3773	3507	4130	3865	3773	3507
C	\$3952	3685	4310	4044	3952	3685

	LNLA	LNLP	LNNA	LNNP	RBLA	RBLP
TW302. 13 A	\$3275	3041	2913	2680	3445	3199
21 A	\$3997	3726	3636	3372	4171	3903
C	\$4180	3911	3818	3553	4354	4085

	RBNA	RBNP	RCLA	RCLP	RCNA	RCNP
TW302. 13 A	\$3081	2840	3411	3169	3051	2809
21 A	\$3807	3539	4130	3865	3773	3507
C	\$3988	3719	4310	4044	3952	3685

	RDLA	RDLP	RDNA	RDNP	RNLA	RNLP
TW302. 13 A	\$3411	3169	3051	2809	3275	3041
21 A	\$4130	3865	3773	3507	3997	3726
C	\$4310	4044	3952	3685	4180	3911

	RNNA	RNNP
TW302. 13 A	\$2913	2680
21 A	\$3636	3372
C	\$3818	3553

Step 8. Top/Side Finish

Solid-Color

For durawrap™ 3D laminate (A)

91	white (CP)	+\$0
LU	soft white	+\$0

Wood-Grain

For durawrap™ 3D laminate (A)

LBA	clear on ash (CP)	+\$10
LBB	oak on ash (CP)	+\$10
LBC	walnut on ash (CP)	+\$10
LBU	medium matte walnut (CP)	+\$10

For 3D laminate (P)

120	light maple woodgrain 3D laminate	+\$0
121	golden maple woodgrain 3D laminate	+\$0
122	brown walnut woodgrain 3D laminate	+\$0
125	light teak woodgrain 3D laminate	+\$25
126	basic white 3D laminate	+\$0

Step 9. Front Finish

Solid-Color

For durawrap™ 3D laminate (A)

91	white (CP)	+\$0
LU	soft white	+\$0

Full Height Storage Cabinet *continued*

Wood-Grain

For durawrap™ 3D laminate (A)

LBA	clear on ash (CP)	+\$10
LBB	oak on ash (CP)	+\$10
LBC	walnut on ash (CP)	+\$10
LBU	medium matte walnut (CP)	+\$10

For 3D laminate (P)

120	light maple woodgrain 3D laminate	+\$0
121	golden maple woodgrain 3D laminate	+\$0
122	brown walnut woodgrain 3D laminate	+\$0
125	light teak woodgrain 3D laminate	+\$25
126	basic white 3D laminate	+\$0

Step 10. Pull Finish

For flex pull (B)

63	fog	+\$0
-----------	-----	------

Half-Height Storage Cabinet

TW305.

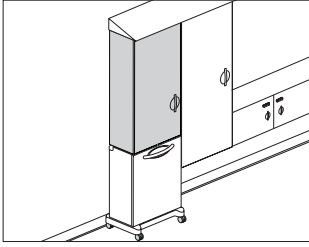

Compass™ Storage

Product Information

Description

This half-height storage cabinet attaches to 2 64"-high rail-attached stiles to provide storage for supplies. It has 3 adjustable shelves. It is 45½" high to allow for a refrigerator, equipment, or linen cart to stow below. If top of cabinet requires a sloped cabinet top close-out, specify separately. The outside of the cabinet and the door front have 3D laminate surfaces. Durawrap™ 3D laminate is a 99.9% PVC-free material.

Notes

For bow pull option (C), pull finish is matte stainless. For arc pull option (D), pull finish is brushed nickel.

Specify close-out, sloped cabinet top (TW406.) separately.

If using a linen cart (TW501.) with this cabinet, specify linen cart tile with backsplash (TW130.BW) separately. Bottom of cabinet has hole template to facilitate installation of linen cart guides included with linen cart tile.

When no linen cart will be used, specify 24" work surface tile with backsplash (TW124.24BW) separately.

Dimensions

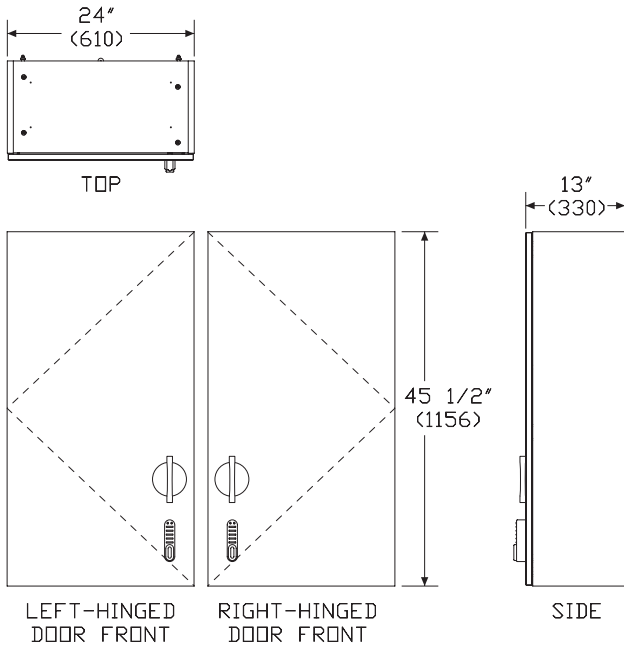

Specification Information

Step 1.

TW305.

Step 2. Depth

13 13" deep

Step 3. Storage Options

H 3 adjustable shelves

Step 4. Door Hinge Location

L left-hinged door

R right-hinged door

Step 5. Pull Type

B flex pull

C bow pull

D arc pull

N no pull

Step 6. Storage Locks

L keyless lock

N no lock

Step 7. Surface Material

A durawrap™ 3D laminate

P 3D laminate

Prices for Steps 1-7.

	LBLA	LBLP	LBNA	LBNP	LCLA	LCLP
TW305. 13 H	\$2892	2654	2526	2288	2865	2623
	LCNA	LCNP	LDLA	LDLP	LDNA	LDNP
TW305. 13 H	\$2502	2266	2865	2623	2502	2266
	LNLA	LNLP	LNNA	LNNP	RBLA	RBLP
TW305. 13 H	\$2728	2493	2374	2132	2892	2654
	RBNA	RBNP	RCLA	RCLP	RCNA	RCNP
TW305. 13 H	\$2526	2288	2865	2623	2502	2266
	RDLA	RDLP	RDNA	RDNP	RNLA	RNLP
TW305. 13 H	\$2865	2623	2502	2266	2728	2493
					RNNA	RNNP
TW305. 13 H					\$2374	2132

Half-Height Storage Cabinet *continued*

Step 8. Top/Side Finish

Solid-Color

For durawrap™ 3D laminate (A)

91	white (CP)	+\$0
LU	soft white	+\$0

Wood-Grain

For durawrap™ 3D laminate (A)

LBA	clear on ash (CP)	+\$10
LBB	oak on ash (CP)	+\$10
LBC	walnut on ash (CP)	+\$10
LBU	medium matte walnut (CP)	+\$10

For 3D laminate (P)

120	light maple woodgrain 3D laminate	+\$0
121	golden maple woodgrain 3D laminate	+\$0
122	brown walnut woodgrain 3D laminate	+\$0
125	light teak woodgrain 3D laminate	+\$25
126	basic white 3D laminate	+\$0

Step 9. Front Finish

Solid-Color

For durawrap™ 3D laminate (A)

91	white (CP)	+\$0
LU	soft white	+\$0

Wood-Grain

For durawrap™ 3D laminate (A)

LBA	clear on ash (CP)	+\$10
LBB	oak on ash (CP)	+\$10
LBC	walnut on ash (CP)	+\$10
LBU	medium matte walnut (CP)	+\$10

For 3D laminate (P)

120	light maple woodgrain 3D laminate	+\$0
121	golden maple woodgrain 3D laminate	+\$0
122	brown walnut woodgrain 3D laminate	+\$0
125	light teak woodgrain 3D laminate	+\$25
126	basic white 3D laminate	+\$0

Step 10. Pull Finish

For flex pull (B)

63	fog	+\$0
-----------	-----	------

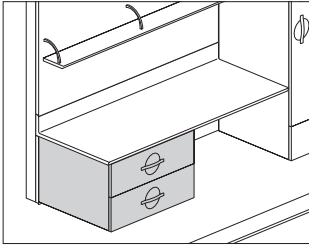

Compass™ Storage

Product Information

Description

This module attaches to 2 rail-attached stiles to provide storage below a work surface and has drawers with full-extension ball-bearing slides. The outside of the module and the drawer fronts have 3D laminate surfaces. Durawrap™ 3D laminate is a 99.9% PVC-free material.

Notes

For bow pull option (C), pull finish is matte stainless. For arc pull option (D), pull finish is brushed nickel.
 Lock option (L) locks the top drawer only.
 Specify work surface (TW210.) separately.
 It is recommended to order a work surface with a backsplash. If ordering a work surface without a backsplash, a special-height mini-tile would need to be ordered.
 Drawer liner will be installed if selected on unit.

Dimensions

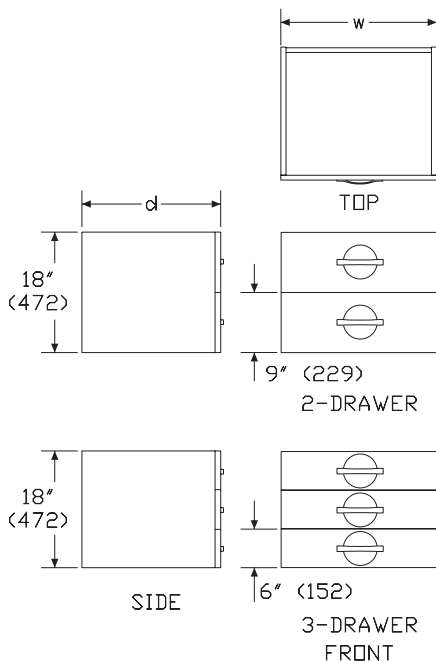

Specification Information

Step 1.

TW310.

Step 2. Depth

- 13 13" deep
- 21 21" deep

Step 3. Width

- 18 18" wide
- 24 24" wide

Step 4. Configuration

- 2 9"-high drawers
- 3 6"-high drawers

Step 5. Pull Type

- B flex pull
- C bow pull
- D arc pull
- N no pull

Step 6. Lock

- L lock
- N no lock

Step 7. Surface Material

- A durawrap™ 3D laminate
- P 3D laminate

Prices for Steps 1-7.

		2BLA	2BLP	2BNA	2BNP	2CLA	2CLP
TW310.	13 18	\$1875	1708	1384	1259	1857	1687
	24	\$1947	1778	1455	1329	1923	1756
	21 18	\$2206	2006	1713	1559	2184	1987
	24	\$2277	2078	1781	1627	2256	2056
		2CNA	2CNP	2DLA	2DLP	2DNA	2DNP
TW310.	13 18	\$1360	1235	1857	1687	1360	1235
	24	\$1433	1309	1923	1756	1433	1309
	21 18	\$1689	1536	2184	1987	1689	1536
	24	\$1758	1605	2256	2056	1758	1605
		2NLA	2NLP	2NNA	2NNP	3BLA	3BLP
TW310.	13 18	\$1831	1666	1338	1213	2043	1859
	24	\$1901	1738	1408	1286	2113	1927

Drawer Module *continued*

	21 18	\$2160	1966	1667	1514	2374	2157	
	24	\$2231	2035	1741	1586	2442	2228	
			3BNA	3BNP	3CLA	3CLP	3CNA	3CNP
TW310. 13	18	\$1550	1407	2006	1827	1513	1374	
	24	\$1619	1477	2078	1897	1585	1448	
	21 18	\$1875	1708	2338	2127	1843	1676	
	24	\$1947	1778	2408	2197	1911	1746	
			3DLA	3DLP	3DNA	3DNP	3NLA	3NLP
TW310. 13	18	\$2006	1827	1513	1374	1975	1794	
	24	\$2078	1897	1585	1448	2044	1865	
	21 18	\$2338	2127	1843	1676	2302	2097	
	24	\$2408	2197	1911	1746	2375	2165	
					3NNA	3NNP		
TW310. 13	18				\$1478	1346		
	24				\$1551	1413		
	21 18				\$1808	1645		
	24				\$1878	1717		

Step 8. Top/Side Finish

Solid-Color

For durawrap™ 3D laminate (A)

91	white (CP)						+\$0
LU	soft white						+\$0

Wood-Grain

For durawrap™ 3D laminate (A)

LBA	clear on ash (CP)						+\$10
LBB	oak on ash (CP)						+\$10
LBC	walnut on ash (CP)						+\$10
LBU	medium matte walnut (CP)						+\$10

For 3D laminate (P)

120	light maple woodgrain 3D laminate	<input type="checkbox"/>					+\$0
121	golden maple woodgrain 3D laminate	<input type="checkbox"/>					+\$0
122	brown walnut woodgrain 3D laminate	<input type="checkbox"/>					+\$0
125	light teak woodgrain 3D laminate	<input type="checkbox"/>					+\$10
126	basic white 3D laminate	<input type="checkbox"/>					+\$0

Step 9. Front Finish

Solid-Color

For durawrap™ 3D laminate (A)

91	white (CP)						+\$0
LU	soft white						+\$0

Wood-Grain

For durawrap™ 3D laminate (A)

LBA	clear on ash (CP)						+\$10
LBB	oak on ash (CP)						+\$10
LBC	walnut on ash (CP)						+\$10
LBU	medium matte walnut (CP)						+\$10

For 3D laminate (P)

120	light maple woodgrain 3D laminate	<input type="checkbox"/>					+\$0
121	golden maple woodgrain 3D laminate	<input type="checkbox"/>					+\$0
122	brown walnut woodgrain 3D laminate	<input type="checkbox"/>					+\$0
125	light teak woodgrain 3D laminate	<input type="checkbox"/>					+\$10
126	basic white 3D laminate	<input type="checkbox"/>					+\$0

Step 10. Pull Finish

For flex pull (B)

63	fog						+\$0
-----------	-----	--	--	--	--	--	------

Step 11. Drawer Liner

For 18" wide (18)

NDL	no drawer liner						+\$0
------------	-----------------	--	--	--	--	--	------

For 24" wide (24) with 9"-high drawers (2)

NDL	no drawer liner						+\$0
DRL	drawer liner						+\$130

For 24" wide (24) with 6"-high drawers (3)

NDL	no drawer liner						+\$0
DRL	drawer liner						+\$225

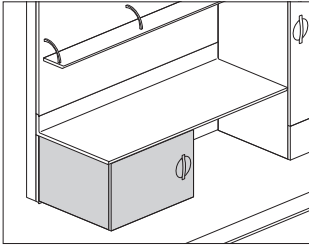

Product Information

Description

This storage cabinet comes in 3 widths and 13" & 21" depths and includes a wall saver. A fixed shelf is located 4" from the bottom of the interior cabinet. Interior cabinet color is white.

Notes

Specify work surface (TW210./TW211.) separately to close off the top.

For power access (P), specify utility support rail (TW170.) and 2 single-gang electrical junction box attachment brackets with or without J-box (TW172.) separately.

It is recommended to order a work surface with a backsplash. If ordering a work surface without a backsplash, a special-height mini-tile would need to be ordered.

For lock option (L), one door has a keyless lock and the other door has a keyed lock.

For the flex pull (B), bow pull (C), and arc pull (D), the doors contain a pocket behind the handle. The no pull (N) door contains no pocket.

Compass™ Storage

Dimensions

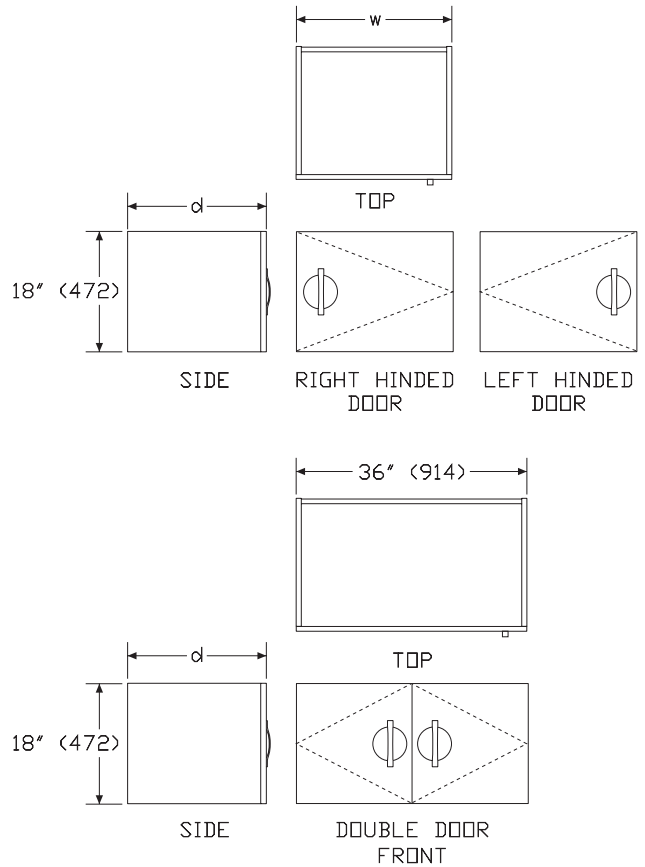

Lower Storage Cabinet with Doors

continued

Specification Information

Step 1.

TW312.

Step 2. Depth

13 13" deep

21 21" deep

Step 3. Width

18 18" wide

24 24" wide

36 36" wide

Step 4. Door

For 18" wide (18) or 24" wide (24)

L left-hinged door

R right-hinged door

For 36" wide (36)

D double doors

Step 5. Pull Type

N no pull

B flex pull

C bow pull

D arc pull

Step 6. Lock

N no lock

L lock

Step 7. Surface Material

A durawrap™ 3D laminate

P 3D laminate

Prices for Steps 1-7.

	DNNA	DNNP	DNLA	DNLP	DBNA	DBNP
TW312. 13 36	\$1422	1298	1874	1711	1484	1355
21 36	\$1723	1572	2176	1986	1788	1630
	DBLA	DBLP	DCNA	DCNP	DCLA	DCLP
TW312. 13 36	\$1939	1766	1453	1325	1905	1740
21 36	\$2241	2043	1755	1600	2210	2013

	DDNA	DDNP	DDLA	DDL P	LNNA	LNNP
TW312. 13 18	—	—	—	—	\$1223	1108
24	—	—	—	—	\$1292	1178
36	\$1741	1588	2132	1946	—	—
21 18	—	—	—	—	\$1526	1384
24	—	—	—	—	\$1595	1453
36	\$1963	1790	2360	2151	—	—
	LNLA	LNLP	LBNA	LBNP	LBLA	LBLP
TW312. 13 18	\$1677	1524	1264	1147	1719	1562
24	\$1745	1593	1334	1217	1788	1630
21 18	\$1978	1798	1567	1423	2020	1835
24	\$2048	1868	1636	1492	2088	1904
	LCNA	LCNP	LCLA	LCLP	LDNA	LDNP
TW312. 13 18	\$1246	1130	1696	1542	1246	1130
24	\$1315	1197	1766	1613	1315	1197
21 18	\$1547	1405	2000	1405	1547	1405
24	\$1616	1473	2071	1885	1616	1473
	LDLA	LDLP	RNNA	RNNP	RNLA	RNLP
TW312. 13 18	\$1696	1542	1223	1108	1677	1524
24	\$1766	1613	1292	1178	1745	1593
21 18	\$2000	1818	1526	1384	1978	1798
24	\$2071	1885	1595	1453	2048	1868
	RBNA	RBNP	RBLA	RBLP	RCNA	RCNP
TW312. 13 18	\$1264	1147	1719	1562	1246	1130
24	\$1334	1217	1788	1630	1315	1197
21 18	\$1567	1423	2020	1835	1547	1405
24	\$1636	1492	2088	1904	1616	1473
	RCLA	RCLP	RDNA	RDNP	RDLA	RDLP
TW312. 13 18	\$1696	1542	1246	1130	1696	1542
24	\$1766	1613	1315	1197	1766	1613
21 18	\$2000	1405	1547	1405	2000	1818
24	\$2071	1885	1616	1473	2071	1885

Step 8. Power Access

N no power access +\$0

P power access +\$30

Compass™ Storage

Lower Storage Cabinet with Doors

continued

Compass™ Storage

Step 9. Top/Side Finish

Solid-Color

For durawrap™ 3D laminate (A)

91	white (CP)	+\$0
LU	soft white	+\$0

Wood-Grain

For durawrap™ 3D laminate (A)

LBA	clear on ash (CP)	+\$10
LBB	oak on ash (CP)	+\$10
LBC	walnut on ash (CP)	+\$10
LBU	medium matte walnut (CP)	+\$10

For 3D laminate (P)

120	light maple woodgrain 3D laminate <input type="checkbox"/>	+\$0
121	golden maple woodgrain 3D laminate <input type="checkbox"/>	+\$0
122	brown walnut woodgrain 3D laminate <input type="checkbox"/>	+\$0
125	light teak woodgrain 3D laminate <input type="checkbox"/>	+\$25
126	basic white 3D laminate <input type="checkbox"/>	+\$0

Step 10. Door Finish

Solid-Color

For durawrap™ 3D laminate (A)

91	white (CP)	+\$0
LU	soft white	+\$0

Wood-Grain

For durawrap™ 3D laminate (A)

LBA	clear on ash (CP)	+\$10
LBB	oak on ash (CP)	+\$10
LBC	walnut on ash (CP)	+\$10
LBU	medium matte walnut (CP)	+\$10

For 3D laminate (P)

120	light maple woodgrain 3D laminate <input type="checkbox"/>	+\$0
121	golden maple woodgrain 3D laminate <input type="checkbox"/>	+\$0
122	brown walnut woodgrain 3D laminate <input type="checkbox"/>	+\$0
125	light teak woodgrain 3D laminate <input type="checkbox"/>	+\$25
126	basic white 3D laminate <input type="checkbox"/>	+\$0

Step 11. Pull Finish

For flex pull (B)

63	fog	+\$0
----	-----	------

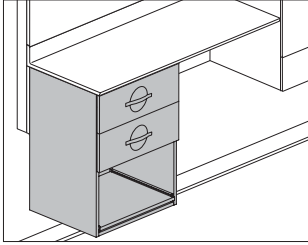

Product Information

Description

This 24"-wide nonpowered storage module attaches to 2 rail-attached stiles to provide storage below a work surface. It has drawers with full-extension ball-bearing slides. Below the drawers is an open cabinet with a fixed-height slide-out shelf to support a printer. Back panel has an 8" x 10" sealed opening for ease of wiring. Cabinet interior has a white melamine surface. The outside of the cabinet has a 3D laminate surface. Durawrap is 99.9% PVC free. Includes a wall saver to protect the architectural wall behind the module.

Notes

For bow pull option (C), pull finish is matte stainless. For arc pull option (D), pull finish is brushed nickel.

Lock option (L) locks the top drawer only.

Specify work surface (TW210.) separately.

It is recommended to order a work surface with a backsplash. If ordering a work surface without a backsplash, a special-height mini-tile would need to be ordered.

Drawer liner will be installed if selected on unit.

Dimensions

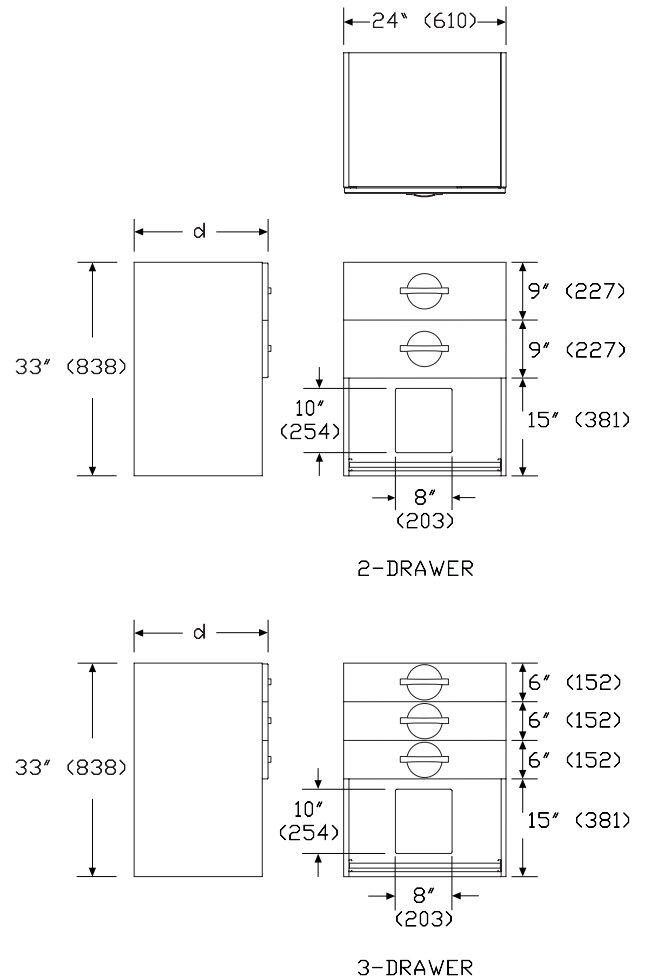

Specification Information

Step 1.

TW314.

Step 2. Depth

- 13** 13" deep
- 21** 21" deep

Step 3. Configuration

- 2** 9"-high drawers
- 3** 6"-high drawers

Step 4. Pull Type

- B** flex pull
- C** bow pull
- D** arc pull
- N** no pull

Step 5. Lock

- L** lock
- N** no lock

Step 6. Surface Material

- A** durawrap™ 3D laminate
- P** 3D laminate A

Prices for Steps 1-6.

		BLA	BLP	BNA	BNP	CLA	CLP
TW314. 13	2	\$2531	2308	2149	1959	2592	2363
	3	\$2747	2504	2370	2157	2843	2591
21	2	\$3088	2815	2708	2469	3151	2873
	3	\$3274	2988	2894	2641	3369	3072
		CNA	CNP	DLA	DLP	DNA	DNP
TW314. 13	2	\$2212	2017	2531	2308	2149	1959
	3	\$2463	2247	2747	2504	2370	2157
21	2	\$2770	2528	3088	2815	2708	2469
	3	\$2988	2723	3274	2988	2894	2641
		NLA	NLP	NNA	NNP		
TW314. 13	2		\$2436	2222	2055	1874	
	3		\$2620	2391	2242	2045	
21	2		\$2994	2729	2612	2384	
	3		\$3148	2871	2769	2526	

Step 7. Top/Side Finish

Solid-Color

For durawrap™ 3D laminate (A)

91	white (CP)	+\$0
LU	soft white	+\$0

Wood-Grain

For durawrap™ 3D laminate (A)

LBA	clear on ash (CP)	+\$10
LBB	oak on ash (CP)	+\$10
LBC	walnut on ash (CP)	+\$10
LBU	medium matte walnut (CP)	+\$10

For 3D laminate (P)

120	light maple woodgrain 3D laminate A	+\$0
121	golden maple woodgrain 3D laminate A	+\$0
122	brown walnut woodgrain 3D laminate A	+\$0
125	light teak woodgrain 3D laminate A	+\$10
126	basic white 3D laminate A	+\$0

Step 8. Front Finish

Solid-Color

For durawrap™ 3D laminate (A)

91	white (CP)	+\$0
LU	soft white	+\$0

Wood-Grain

For durawrap™ 3D laminate (A)

LBA	clear on ash (CP)	+\$10
LBB	oak on ash (CP)	+\$10
LBC	walnut on ash (CP)	+\$10
LBU	medium matte walnut (CP)	+\$10

For 3D laminate (P)

120	light maple woodgrain 3D laminate A	+\$0
121	golden maple woodgrain 3D laminate A	+\$0
122	brown walnut woodgrain 3D laminate A	+\$0
125	light teak woodgrain 3D laminate A	+\$10
126	basic white 3D laminate A	+\$0

Step 9. Pull Finish

For flex pull (B)

63	fog	+\$0
-----------	-----	------

Drawer and Printer Module *continued*

Step 10. Drawer Liner

For 9"-high drawers (2)

NDL	no drawer liner	+\$0
DRL	drawer liner	+\$130

For 6"-high drawers (3)

NDL	no drawer liner	+\$0
DRL	drawer liner	+\$225

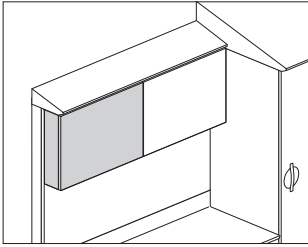

Compass™ Storage

Product Information

Description

This non-locking cabinet attaches to 2 rail-attached stiles in the upper tile position to provide small and medium item storage. Hinged door(s) have a magnetic closure. Cabinet interior has white melamine surface. The outside of the cabinet has a 3D laminate surface. Durawrap™ 3D laminate is a 99.9% PVC-free material.

Notes

For 13" deep upper storage cabinet (13), order 21" deep lower storage products.

For 6" deep (06) or 9" deep upper storage cabinet (09), order 13" deep or 21" deep lower storage products.

Dimensions

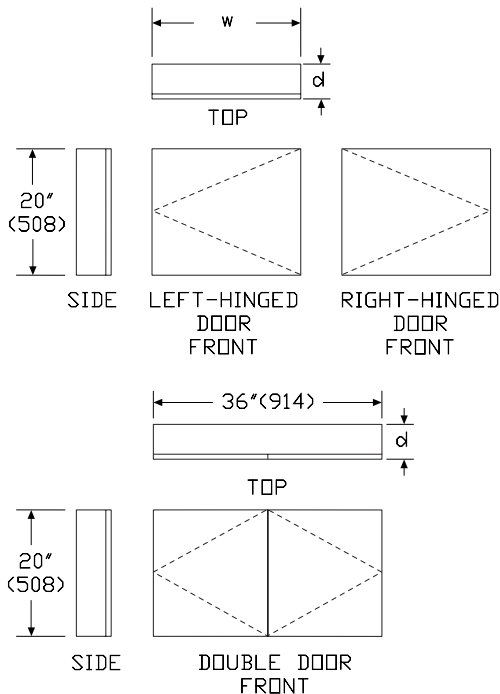

Specification Information

Step 1.

TW320.

Step 2. Depth

- 06** 6" deep
- 09** 9" deep
- 13** 13" deep

Step 3. Width

- 18** 18" wide
- 24** 24" wide
- 30** 30" wide
- 36** 36" wide

Step 4. Door Hinge Location

For 18" wide (18), 24" wide (24), or 30" wide (30)

- L** left-hinged door
- R** right-hinged door

For 36" wide (36)

- D** double doors

Step 5. Surface Material

- A** durawrap™ 3D laminate
- P** 3D laminate

Prices for Steps 1-5.

		DA	DP	LA	LP	RA	RP
TW320. 06	18	—	—	\$706	606	706	606
	24	—	—	\$837	763	837	763
	30	—	—	\$1221	1113	1221	1113
	36	\$1302	1185	—	—	—	—
09	18	—	—	\$875	757	875	757
	24	—	—	\$952	867	952	867
	30	—	—	\$1373	1252	1373	1252
	36	\$1410	1283	—	—	—	—
13	18	—	—	\$1040	905	1040	905
	24	—	—	\$1127	1027	1127	1027
	30	—	—	\$1547	1410	1547	1410
	36	\$1577	1436	—	—	—	—

Storage Cabinet *continued*

Step 6. Top/Side Finish

Solid-Color

For durawrap™ 3D laminate (A)

91	white (CP)	+\$0
LU	soft white	+\$0

Wood-Grain

For durawrap™ 3D laminate (A)

LBA	clear on ash (CP)	+\$10
LBB	oak on ash (CP)	+\$10
LBC	walnut on ash (CP)	+\$10
LBU	medium matte walnut (CP)	+\$10

For 3D laminate (P)

120	light maple woodgrain 3D laminate <input type="checkbox"/>	+\$0
121	golden maple woodgrain 3D laminate <input type="checkbox"/>	+\$0
122	brown walnut woodgrain 3D laminate <input type="checkbox"/>	+\$0
125	light teak woodgrain 3D laminate <input type="checkbox"/>	+\$10
126	basic white 3D laminate <input type="checkbox"/>	+\$0

Step 7. Door Finish

Solid-Color

For durawrap™ 3D laminate (A)

91	white (CP)	+\$0
LU	soft white	+\$0

Wood-Grain

For durawrap™ 3D laminate (A)

LBA	clear on ash (CP)	+\$10
LBB	oak on ash (CP)	+\$10
LBC	walnut on ash (CP)	+\$10
LBU	medium matte walnut (CP)	+\$10

For 3D laminate (P)

120	light maple woodgrain 3D laminate <input type="checkbox"/>	+\$0
121	golden maple woodgrain 3D laminate <input type="checkbox"/>	+\$0
122	brown walnut woodgrain 3D laminate <input type="checkbox"/>	+\$0
125	light teak woodgrain 3D laminate <input type="checkbox"/>	+\$10
126	basic white 3D laminate <input type="checkbox"/>	+\$0

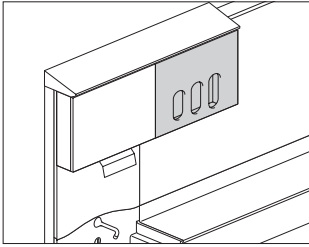

Compass™ Storage

Product Information

Description
 This non-locking cabinet attaches to 2 rail-attached stiles in the upper tile position and holds 3 boxes of gloves. The interior allows for additional storage. The outside of the cabinet and the door front have 3D laminate surfaces. Durawrap™ 3D laminate is a 99.9% PVC-free material.

Dimensions

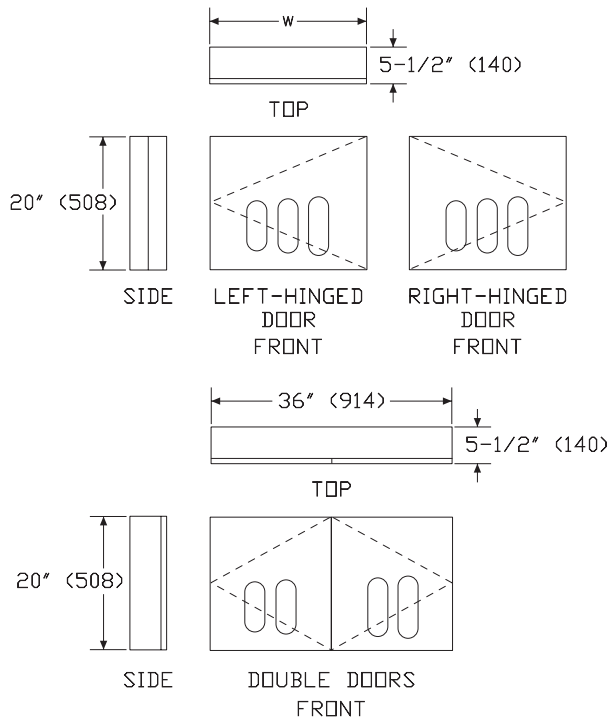

Specification Information

Step 1.

TW322.06

Step 2. Width

- 24 24" wide
- 30 30" wide
- 36 36" wide

Step 3. Door Hinge Location

For 24" wide (24) or 30" wide (30)

- L left-hinged door
- R right-hinged door

For 36" wide (36)

- D double doors

Step 4. Surface Material

- A durawrap™ 3D laminate
- P 3D laminate

Prices for Steps 1-4.

		A	P
TW322.06	24 L	\$952	868
	R	\$952	868
	30 L	\$1375	1255
	R	\$1375	1255
	36 D	\$1449	1322

Step 5. Top/Side Finish

Solid-Color

For durawrap™ 3D laminate (A)

- 91 white (CP) +\$0
- LU soft white +\$0

Wood-Grain

For durawrap™ 3D laminate (A)

- LBA clear on ash (CP) +\$10
- LBB oak on ash (CP) +\$10
- LBC walnut on ash (CP) +\$10
- LBU medium matte walnut (CP) +\$10

Glove Cabinet *continued*

For 3D laminate (P)

120	light maple woodgrain 3D laminate	A	+\$0
121	golden maple woodgrain 3D laminate	A	+\$0
122	brown walnut woodgrain 3D laminate	A	+\$0
125	light teak woodgrain 3D laminate	A	+\$10
126	basic white 3D laminate	A	+\$0

Step 6. Door Finish

Solid-Color

For durawrap™ 3D laminate (A)

91	white (CP)		+\$0
LU	soft white		+\$0

Wood-Grain

For durawrap™ 3D laminate (A)

LBA	clear on ash (CP)		+\$10
LBB	oak on ash (CP)		+\$10
LBC	walnut on ash (CP)		+\$10
LBU	medium matte walnut (CP)		+\$10

For 3D laminate (P)

120	light maple woodgrain 3D laminate	A	+\$0
121	golden maple woodgrain 3D laminate	A	+\$0
122	brown walnut woodgrain 3D laminate	A	+\$0
125	light teak woodgrain 3D laminate	A	+\$10
126	basic white 3D laminate	A	+\$0

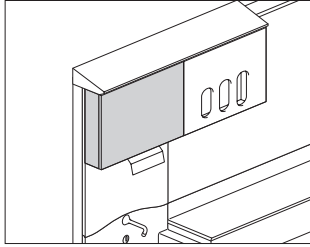

Compass™ Storage

Product Information

Description

This non-locking cabinet attaches to 2 rail-attached stiles in the upper tile position to cover a field-supplied paper towel dispenser. The interior allows for storage of additional paper towels. The outside of the cabinet and the door front have 3D laminate surfaces. Durawrap™ 3D laminate is a 99.9% PVC-free material.

Dimensions

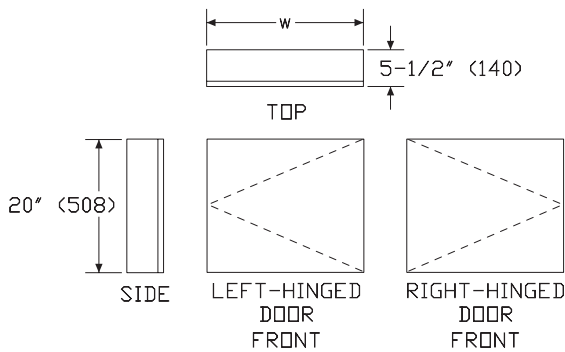

Specification Information

Step 1.

TW324.06

Step 2. Width

24 24" wide

Step 3. Door Hinge Location

L left-hinged door

R right-hinged door

Step 4. Surface Material

A durawrap™ 3D laminate

P 3D laminate A

Prices for Steps 1-4.

		A	P
TW324.06	24 L	\$911	836
	R	\$911	836

Step 5. Top/Side Finish

Solid-Color

For durawrap™ 3D laminate (A)

91	white (CP)	+\$0
LU	soft white	+\$0

Wood-Grain

For durawrap™ 3D laminate (A)

LBA	clear on ash (CP)	+\$10
LBB	oak on ash (CP)	+\$10
LBC	walnut on ash (CP)	+\$10
LBU	medium matte walnut (CP)	+\$10

For 3D laminate (P)

120	light maple woodgrain 3D laminate <input type="checkbox"/> A	+\$0
121	golden maple woodgrain 3D laminate <input type="checkbox"/> A	+\$0
122	brown walnut woodgrain 3D laminate <input type="checkbox"/> A	+\$0
126	basic white 3D laminate <input type="checkbox"/> A	+\$0
125	light teak woodgrain 3D laminate <input type="checkbox"/> A	+\$10

Step 6. Door Finish

Solid-Color

For durawrap™ 3D laminate (A)

91	white (CP)	+\$0
LU	soft white	+\$0

Paper Towel Cabinet *continued*

Wood-Grain

For durawrap™ 3D laminate (A)

LBA	clear on ash (CP)	+\$10
LBB	oak on ash (CP)	+\$10
LBC	walnut on ash (CP)	+\$10
LBU	medium matte walnut (CP)	+\$10

For 3D laminate (P)

120	light maple woodgrain 3D laminate <input type="checkbox"/> A	+\$0
121	golden maple woodgrain 3D laminate <input type="checkbox"/> A	+\$0
122	brown walnut woodgrain 3D laminate <input type="checkbox"/> A	+\$0
126	basic white 3D laminate <input type="checkbox"/> A	+\$0
125	light teak woodgrain 3D laminate <input type="checkbox"/> A	+\$10

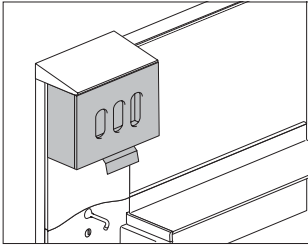

Product Information

Description

This non-locking combination glove and towel cabinet attaches to 2 rail-attached stiles in the upper tile position and holds 3 boxes of gloves and a field supplied paper towel dispenser. Hinged door(s) have a magnetic closure. Cabinet interior has a white melamine surface. The paper towel cabinet is in the back center of the cabinet in all sizes. The outside of the cabinet has a 3D laminate surface. Durawrap™ 3D laminate is a 99.9% PVC-free material.

Notes

It is recommended to leave an empty box (if a particular glove size is diminished) to hold the other boxes in place.
 There is extra storage space on the top shelf (included) for 2 additional boxes of gloves (horizontally) for 24"-wide cabinets and for 3 additional boxes of gloves for 36"-wide cabinets.

Dimensions

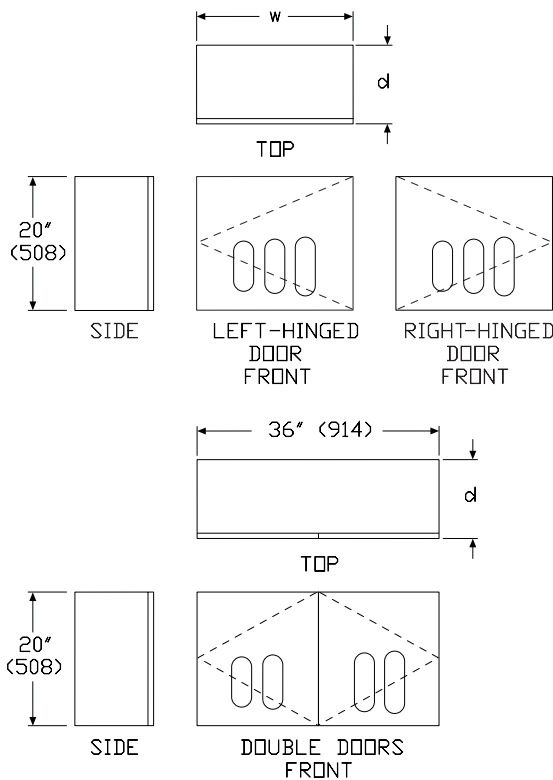

Specification Information

Step 1.

TW326.

Step 2. Depth

- 09 9" deep
- 13 13" deep

Step 3. Width

- 24 24" wide
- 30 30" wide
- 36 36" wide

Step 4. Door Hinge Location

For 24" wide (24) or 30" wide (30)

- L left-hinged door
- R right-hinged door

For 36" wide (36)

- D double doors

Step 5. Surface Material

- A durawrap™ 3D laminate
- P 3D laminate

Prices for Steps 1-5.

	DA	DP	LA	LP	RA	RP
TW326. 09 24	—	—	\$1175	1073	1175	1073
30	—	—	\$1428	1302	1428	1302
36	\$1680	1532	—	—	—	—
13 24	—	—	\$1326	1211	1326	1211
30	—	—	\$1587	1448	1587	1448
36	\$1847	1687	—	—	—	—

Step 6. Top/Side Finish

Solid-Color

For durawrap™ 3D laminate (A)

- 91 white (CP) +\$0
- LU soft white +\$0

Glove and Paper Combo Cabinet

continued

Wood-Grain

For durawrap™ 3D laminate (A)

LBA	clear on ash (CP)	+\$10
LBB	oak on ash (CP)	+\$10
LBC	walnut on ash (CP)	+\$10
LBU	medium matte walnut (CP)	+\$10

For 3D laminate (P)

120	light maple woodgrain 3D laminate <input type="checkbox"/>	+\$0
121	golden maple woodgrain 3D laminate <input type="checkbox"/>	+\$0
122	brown walnut woodgrain 3D laminate <input type="checkbox"/>	+\$0
125	light teak woodgrain 3D laminate <input type="checkbox"/>	+\$10
126	basic white 3D laminate <input type="checkbox"/>	+\$0

Step 7. Door Finish

Solid-Color

For durawrap™ 3D laminate (A)

91	white (CP)	+\$0
LU	soft white	+\$0

Wood-Grain

For durawrap™ 3D laminate (A)

LBA	clear on ash (CP)	+\$10
LBB	oak on ash (CP)	+\$10
LBC	walnut on ash (CP)	+\$10
LBU	medium matte walnut (CP)	+\$10

For 3D laminate (P)

120	light maple woodgrain 3D laminate <input type="checkbox"/>	+\$0
121	golden maple woodgrain 3D laminate <input type="checkbox"/>	+\$0
122	brown walnut woodgrain 3D laminate <input type="checkbox"/>	+\$0
125	light teak woodgrain 3D laminate <input type="checkbox"/>	+\$10
126	basic white 3D laminate <input type="checkbox"/>	+\$0

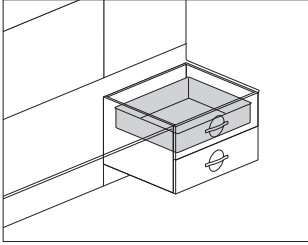

Product Information

Description

This plastic insert fits into drawers in a drawer module or wardrobe cabinet to help with infection control. It has radius edges for easy wipe-down. Finish is white.

Dimensions

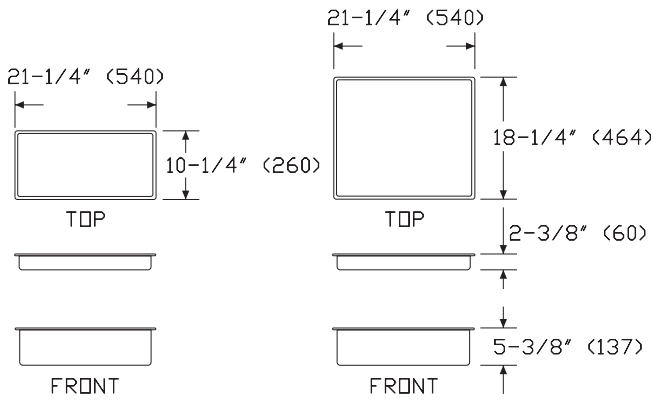

Specification Information

Step 1.

TW390.

Step 2. Depth

- 13** 13" deep
- 21** 21" deep

Step 3. Height

- 06** 6" high
- 09** 9" high

Prices for Steps 1-3.

	06	09
TW390. 13	\$92	102
21	\$110	117

Waste Receptacle Cabinet

TW316.

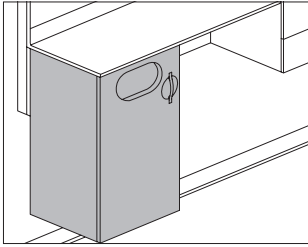

Product Information

Description

This waste cabinet attaches to 2 rail-attached stiles to provide storage for a waste receptacle below a work surface. A slim profile bracket attaches to the door that holds the waste receptacle. Cabinet is designed to accommodate a 7-gallon or 10-gallon waste bin. Door is available with a cutout to allow touch-free access to the waste bin. Cabinet interior has a white melamine surface. The outside of the cabinet has a 3D laminate surface. Durawrap™ 3D laminate is a 99.9% PVC-free material. Includes a wall saver to protect the architectural wall behind the module.

Notes

Waste bin not included. See Planning Guide for recommendations.

For bow pull option (C), pull finish is matte stainless. For arc pull option (D), pull finish is brushed nickel.

Specify work surface (TW210.) separately.

It is recommended to order a work surface with a backsplash. If ordering a work surface without a backsplash, a special-height mini-tile would need to be ordered.

For flex pull (B), bow pull (C), and arc pull (D) options, the doors contain a pocket behind the handle. The no pull (N) door contains no pocket.

Dimensions

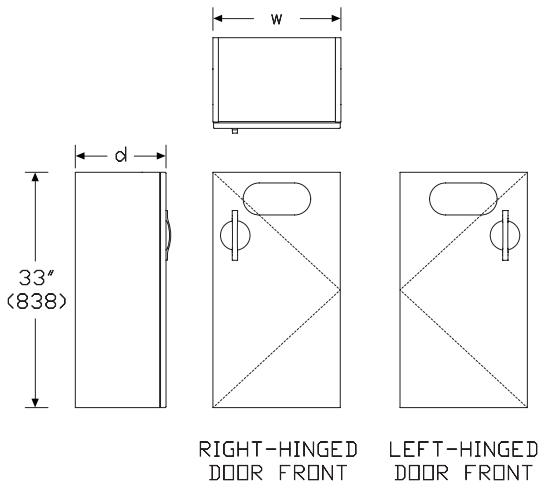

Specification Information

Step 1.

TW316. A

Step 2. Depth

13 13" deep A

21 21" deep A

Step 3. Width

18 18" wide A

24 24" wide A

Step 4. Door

L left-hinged door A

R right-hinged door A

Step 5. Cutout Option

N no cutout A

C cutout A

Step 6. Pull Type

B flex pull A

C bow pull A

D arc pull A

N no pull A

Step 7. Surface Material

A durawrap™ 3D laminate A

P 3D laminate A

Prices for Steps 1-7.

			LNBA	LBNP	LNCA	LNCP	LNDA	LNDP
TW316.	13	18	\$1473	1300	1500	1330	1473	1300
		24	\$1545	1371	1575	1400	1545	1371
	21	18	\$1749	1544	1780	1571	1749	1544
		24	\$1853	1630	1878	1662	1852	1630
			LNNA	LNNP	LCBA	LCBP	LCCA	LCCP
TW316.	13	18	\$1428	1257	1489	1315	1519	1348
		24	\$1499	1328	1563	1387	1592	1419
	21	18	\$1706	1497	1766	1560	1796	1589
		24	\$1805	1588	1868	1649	1897	1680
			LCDA	LCDP	LCNA	LCNP	RNBA	RBNP
TW316.	13	18	\$1489	1317	1445	1271	1473	1300
		24	\$1563	1387	1516	1345	1545	1371

Waste Receptacle Cabinet *continued*

Compass™ Storage

	21	18	\$1766	1560	1722	1514	1749	1544
	24		\$1866	1649	1824	1603	1853	1630
			RCNA	RCNP	RNDA	RNDP	RNNA	RNNP
TW316.13	18		\$1500	1330	1473	1300	1428	1257
	24		\$1575	1400	1545	1371	1499	1328
	21	18	\$1780	1571	1749	1544	1706	1497
	24		\$1878	1662	1852	1630	1805	1588
			RCBA	RCBP	RCCA	RCCP	RCDA	RCDP
TW316.13	18		\$1489	1315	1519	1348	1489	1317
	24		\$1563	1387	1592	1419	1563	1387
	21	18	\$1766	1560	1796	1589	1766	1560
	24		\$1868	1649	1897	1680	1866	1649
					RCNA	RCNP		
TW316.13	18				\$1445	1271		
	24				\$1516	1345		
	21	18			\$1722	1514		
	24				\$1824	1603		

Step 8. Top/Side Finish

For 3D laminate (P)

120	light maple woodgrain 3D laminate	A	+\$0
121	golden maple woodgrain 3D laminate	A	+\$0
122	brown walnut woodgrain 3D laminate	A	+\$0
125	light teak woodgrain 3D laminate	A	+\$10
126	basic white 3D laminate	A	+\$0

For durawrap™ 3D laminate (A)

91	white (CP)	A	+\$0
LU	soft white	A	+\$0

For durawrap™ 3D laminate (A)

LBA	clear on ash (CP)	A	+\$10
LBB	oak on ash (CP)	A	+\$10
LBC	walnut on ash (CP)	A	+\$10
LBU	medium matte walnut (CP)	A	+\$10

Step 9. Door Finish

For durawrap™ 3D laminate (A)

91	white (CP)	A	+\$0
LU	soft white	A	+\$0

For durawrap™ 3D laminate (A)

LBA	clear on ash (CP)	A	+\$10
LBB	oak on ash (CP)	A	+\$10
LBC	walnut on ash (CP)	A	+\$10
LBU	medium matte walnut (CP)	A	+\$10

For 3D laminate (P)

120	light maple woodgrain 3D laminate	A	+\$0
121	golden maple woodgrain 3D laminate	A	+\$0
122	brown walnut woodgrain 3D laminate	A	+\$0
125	light teak woodgrain 3D laminate	A	+\$10
126	basic white 3D laminate	A	+\$0

Step 10. Pull Finish

For flex pull (B)

63	fog	A	+\$0
----	-----	---	------

Close-out, Side

TW400.

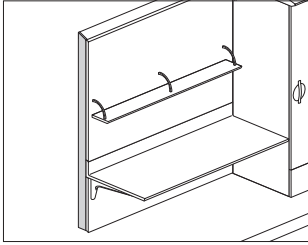

Product Information

Description

This plastic close-out finishes the exposed side of a stile at the end of a wall rail.

Notes

When wall rails extend past the stile and close-out, specify cutout(s) for wall rail option (C). Finish the cutouts with close-out grommet (TW409.), specified separately.

Close-out with cutout(s) for wall rail option (C) has 1 cutout for 24"-high, 2 cutouts for 64" and 89"-high.

When close-out, sloped cabinet top (TW406.) or chase tile (TW182.) is present, an 89" close-out, side is required and must be field cut to height. Top edge of close-out is flat.

Dimensions

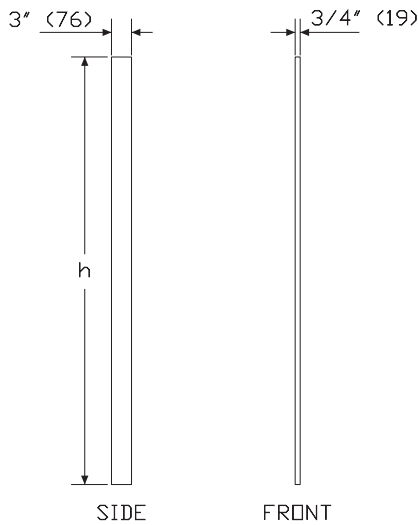

Specification Information

Step 1.

TW400.

Step 2. Height

- 24** 24" high
- 64** 64" high
- 89** 89" high

Step 3. Type

- L** left
- R** right

Step 4. Cutout

- C** cutout(s) for wall rail
- N** no cutout(s) for wall rail

Prices for Steps 1-4.

	C	N
TW400. 24 L	\$56	43
R	\$56	43
64 L	\$95	65
R	\$95	65
89 L	\$141	111
R	\$141	111

Step 5. Surface Finish

- 91** white (CP) +\$0
- LU** soft white +\$0

Close-out, Top

TW402.

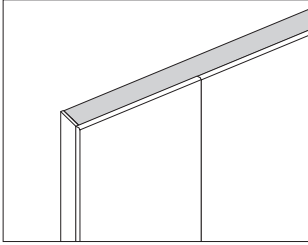

Compass™ Close-Outs

Product Information

Description

This aluminum close-out finishes the gap between the architectural wall and tiles at the top of rail-attached stiles. It has a 20° slope for ease of cleaning and infection control. It can be field-cut to match the width of the wall, or to accommodate a chase. Attachment hardware included.

Notes

When close-out, sloped cabinet top (TW406.) or chase tile (TW182.) is used in combination with the top close-out, the top close-out must be specified in the next larger size for the applied module span and must be field cut down to that module span.

If no sloped top or chase tile is present, the top close-out width should match the overall module width.

Dimensions

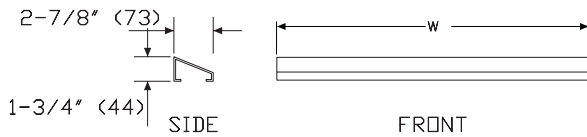

Specification Information

Step 1.

TW402.

Step 2. Application

A for use between two side closeouts

Step 3. Width

For use between two side closeouts (A)

- 18 18" wide A
- 24 24" wide
- 36 36" wide
- 48 48" wide
- 60 60" wide
- 72 72" wide
- 84 84" wide
- 96 96" wide

Prices for Steps 1-3.

	18	24	36	48	60	72
TW402. A	\$83	90	94	99	115	130
					84	96
TW402. A					\$146	169

Step 4. Surface Finish

91	white (CP)					+\$0
LU	soft white					+\$0

Close-out, Bottom

TW404.

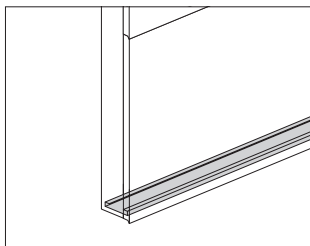

Product Information

Description

This plastic close-out finishes the gap between the architectural wall and tiles at the bottom of rail-attached stiles. It can be field-cut to match the width of the wall. Attachment hardware included.

Dimensions

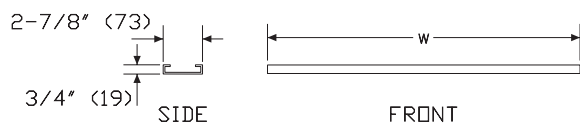

Specification Information

Step 1.

TW404.

Step 2. Width

18	18" wide
24	24" wide
36	36" wide
48	48" wide
60	60" wide
72	72" wide
84	84" wide
96	96" wide

Step 3. Application

- A not for use next to bed tile
- B for use next to bed tile

Prices for Steps 1-3.

	A	B
TW404. 18	\$43	43
24	\$46	46
36	\$51	51
48	\$55	55
60	\$68	68
72	\$79	79
84	\$88	88
96	\$106	106

Step 4. Surface Finish

91	white (CP)	+\$0
LU	soft white	+\$0

Compass™ Close-Outs

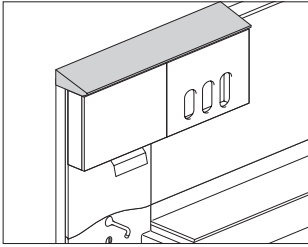

Compass™ Close-Outs

Product Information

Description

This steel sloped top finishes the top of a wardrobe cabinet, storage cabinet, glove cabinet, or paper towel cabinet. Close-out can span multiple cabinets.

Notes

Specify 6" deep option (06) for storage cabinet, glove cabinet, or paper towel cabinet.

Specify 9" deep option (09) for storage cabinet or glove and paper combo cabinet.

Specify 13" deep option (13) for 13"-deep wardrobe cabinet, storage cabinet, or glove and paper combo cabinet.

Specify 21" deep option (21) for 21"-deep wardrobe cabinet.

Dimensions

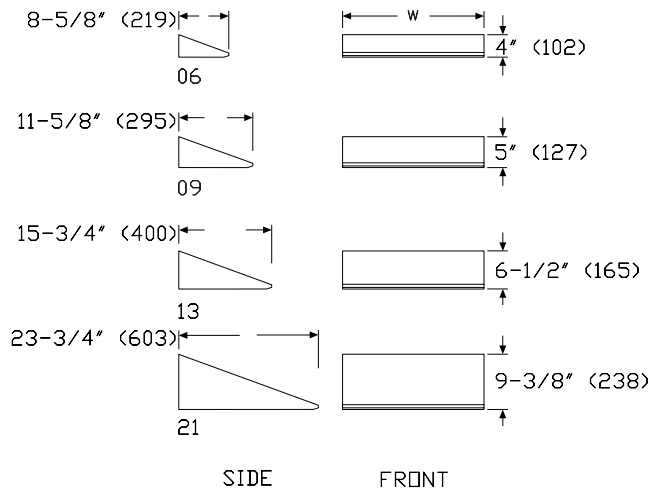

Specification Information

Step 1.

TW406.

Step 2. Depth

- 06 6" deep
- 09 9" deep
- 13 13" deep
- 21 21" deep

Step 3. Width

For 6" deep (06)

- 18 18" wide
- 24 24" wide
- 30 30" wide
- 36 36" wide
- 42 42" wide
- 48 48" wide
- 54 54" wide
- 60 60" wide
- 66 66" wide
- 72 72" wide
- 84 84" wide
- 96 96" wide

For 9" deep (09) or 13" deep (13)

- 18 18" wide
- 24 24" wide
- 30 30" wide
- 36 36" wide
- 42 42" wide
- 48 48" wide
- 54 54" wide
- 60 60" wide
- 66 66" wide
- 72 72" wide

For 21" deep (21)

- 24 24" wide

Prices for Steps 1-3.

	18	24	30	36	42	48
TW406. 06	\$117	126	131	142	146	150
09	\$121	137	140	150	174	196
13	\$148	167	182	203	217	238
21	—	\$228	—	—	—	—

Close-out, Sloped Cabinet Top

continued

	54	60	66	72	84	96
TW406. 06	\$154	163	172	178	182	190
09	\$204	215	237	262	—	—
13	\$270	302	332	360	—	—

Step 4. Surface Finish

91	white (CP)					+\$0
LU	soft white					+\$0

Grommet, Close-out

TW409.

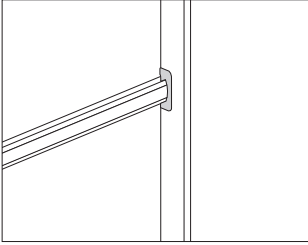

Product Information

Description
 This individual grommet attaches to a side close-out with cutouts to fill the gap when the wall rail extends past the close-out.

Dimensions

Specification Information

Step 1.
TW409. \$34

Step 2. Surface Finish

Solid-Color
91 white (CP) + \$0

Compass™ Close-Outs

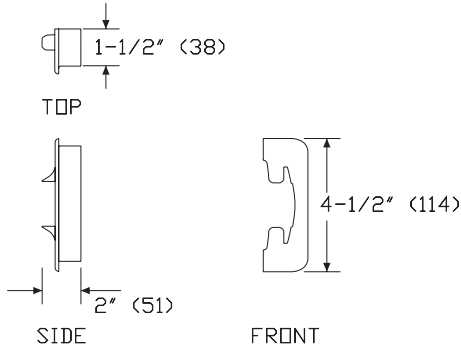

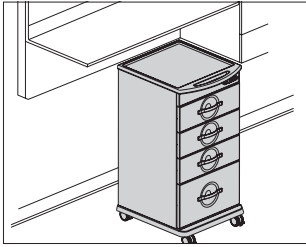

Product Information

Description

This supply cart provides mobile storage. It comes in several sizes with no lock, keyed lock, and keyless lock options. Base finish is cool grey neutral with wall saver function in all directions. Front casters lock. Case finish applies throughout.

Notes

39" height fits under a 39"-high counter with a 1" gap.

Order the following products separately:

- Corian® work surface (TW21x.xxxxK)
- Cantilever (TW219.)

Dimensions

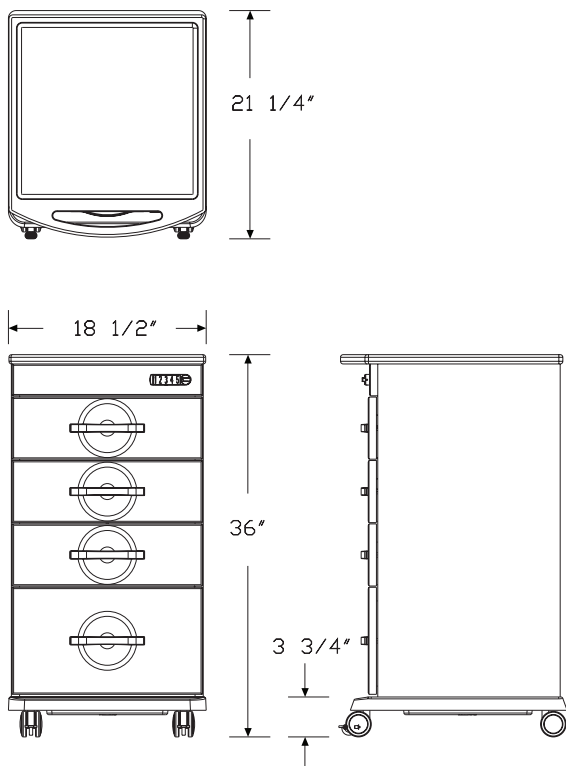

Specification Information

Step 1.

TW503. [A]

Step 2. Height

39 for use with 39" high work surface [A] +\$3997

Step 3. Width

18 18" wide [A] +\$0

Step 4. Depth

19 19" deep [A] +\$0

Step 5. Storage Options

4 (3) 6"-high drawers and (1) 9"-high drawer [A] +\$0

Step 6. Lock Option

NL no lock [A] +\$0
KP keyless lock [A] +\$389

Step 7. Pull Type

N no pull [A] +\$0
B flex pull [A] +\$99
C bow pull [A] +\$157
D arc pull [A] +\$145

Step 8. Case/Front/Side Material

A durawrap™ 3D laminate [A] +\$67
P 3D laminate [A] +\$0

Step 9. Top Material

R impact resistant ABS thermoformed top [A] +\$0
C corian [A] +\$725

Step 10. Drawer Glide

SDG standard drawer glide [A] +\$0

Step 11. Caster Option

C 2" black caster, soft casters for hard floors [A] +\$0

Step 12. Case/Front/Side Finish

For durawrap™ 3D laminate (A)

91 white (CP) [A] +\$0
LU soft white [A] +\$0

Supply Cart *continued*

Compass™ Transport

For durawrap™ 3D laminate (A)

LBA	clear on ash (CP) <input type="checkbox"/>	+\$10
LBB	oak on ash (CP) <input type="checkbox"/>	+\$10
LBC	walnut on ash (CP) <input type="checkbox"/>	+\$10
LBU	medium matte walnut (CP) <input type="checkbox"/>	+\$10

For 3D laminate (P)

120	light maple woodgrain 3D laminate <input type="checkbox"/>	+\$0
121	golden maple woodgrain 3D laminate <input type="checkbox"/>	+\$0
122	brown walnut woodgrain 3D laminate <input type="checkbox"/>	+\$0
125	light teak woodgrain 3D laminate <input type="checkbox"/>	+\$0
126	basic white 3D laminate <input type="checkbox"/>	+\$0

Step 13. Top Finish

For corian (C)

1S	savannah <input type="checkbox"/>	+\$155
1U	sahara <input type="checkbox"/>	+\$155
4I	sandstone <input type="checkbox"/>	+\$155
58	cameo white <input type="checkbox"/>	+\$0
ANC	antarctica <input type="checkbox"/>	+\$155
CQ	glacier white <input type="checkbox"/>	+\$0
CRT	concrete <input type="checkbox"/>	+\$240
DVC	dove <input type="checkbox"/>	+\$240
IQ	aurora <input type="checkbox"/>	+\$155
OQ	silt <input type="checkbox"/>	+\$155
QB	bisque <input type="checkbox"/>	+\$0

For impact resistant ABS thermoformed top (R)

98	studio white (CP) <input type="checkbox"/>	+\$0
-----------	--	------

Step 14. Base Finish

CL	cool grey neutral <input type="checkbox"/>	+\$0
-----------	--	------

Step 15. Pull Finish

For flex pull (B)

63	fog <input type="checkbox"/>	+\$0
-----------	------------------------------	------

Linen Cart

TW501.

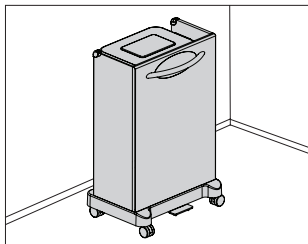

Product Information

Description

This cart holds linens and has a top ring that accommodates a standard "blue" linen bag. It docks below a work surface with linen cart tile. Front and side panels are 3D laminate. Durawrap™ 3D laminate is a 99.9% PVC-free material. Side panels are 91 white 3D laminate. Top ring and pull finish are metallic silver. Lid, foot pedal, and base finish are cool grey neutral.

Notes

Foot pedal is on front of cart.

Cart lid opens to the left.

Cart comes with side panels in white (91) Durawrap 3D laminate.

Cart cannot be cleaned using a cart wash.

Specify the following products separately:

- Cantilever (TW219.)
- Linen cart tile (TW130.)
- Work surface (TW210.)

Dimensions

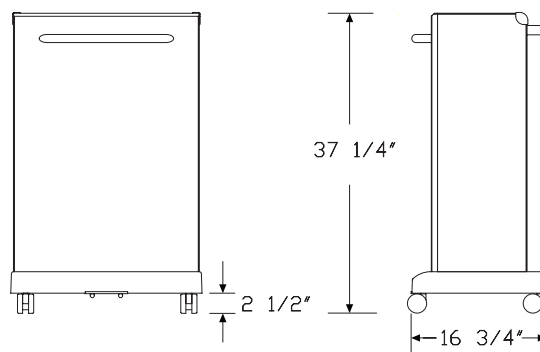
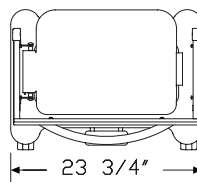

Cart with lid and foot pedal

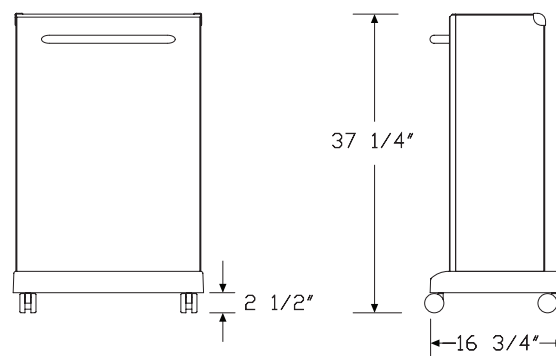
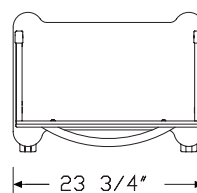

Cart with no lid and no foot pedal

Compass™ Transport

Linen Cart *continued*

Compass™ Transport

Specification Information

Step 1.

TW501. A

Step 2. Type

N no lid or foot pedal A

M lid and no foot pedal A

L lid and foot pedal A

Step 3. Surface Material

A durawrap™ 3D laminate A

P 3D laminate A

Prices for Steps 1-3.

	A	P
TW501. N	\$1863	1811
M	\$2225	2163
L	\$2424	2356

Step 4. Side Finish

91 white (CP) A +\$0

Step 5. Front Finish

Solid-Color

For durawrap™ 3D laminate (A)

91 white (CP) A +\$0

LU soft white A +\$0

Wood-Grain

For durawrap™ 3D laminate (A)

LBA clear on ash (CP) A +\$10

LBB oak on ash (CP) A +\$10

LBC walnut on ash (CP) A +\$10

LBU medium matte walnut (CP) A +\$10

For 3D laminate (P)

120 light maple woodgrain 3D laminate A +\$0

121 golden maple woodgrain 3D laminate A +\$0

122 brown walnut woodgrain 3D laminate A +\$0

125 light teak woodgrain 3D laminate A +\$10

126 basic white 3D laminate A +\$0

Accessory Rail

TW700.

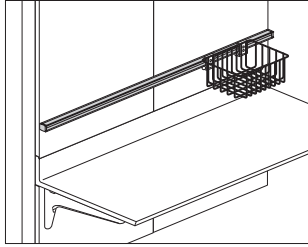

Product Information

Description

This aluminum rail attaches to the front of a tile to hold rail-mounted components. It has a satin oxide laminate insert and grey end caps. Attachment hardware included.

Notes

Rail can match tile width, or span multiple tiles. For easy removal of tiles, accessory rail width should be equal to or less than the width of the tile it's attached to.

Dimensions

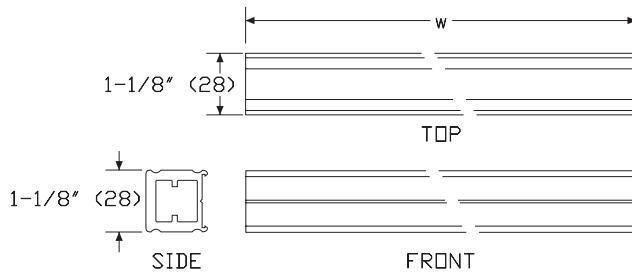

Specification Information

Step 1.

TW700.

Step 2. Width

18	18" wide
24	24" wide
30	30" wide
36	36" wide
42	42" wide
48	48" wide

Prices for Steps 1-2.

TW700. 18	\$102
24	\$135
30	\$170
36	\$202
42	\$234
48	\$264

Universal Rail Clamp

TW705.

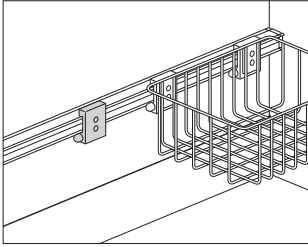

Product Information

Description

This universal aluminum clamp attaches to an accessory rail and has holes for attaching customer supplied components. It has a push button mechanism that locks the clamp in place and allows for easy attachment and removal.

Notes

Order accessory rail (TW700.) separately.

Dimensions

Specification Information

Step 1.

TW705.

\$172

Compass™ Rails and Accessories

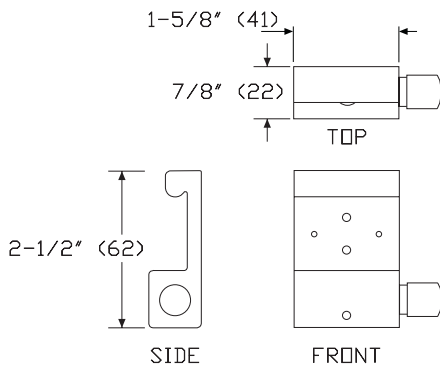

Soap and Sanitizer Mounting Bracket TW706.

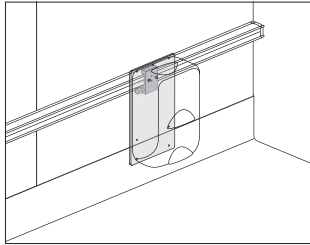

Product Information

Description

This aluminum mounting bracket is designed for use with customer supplied components such as soap and sanitizer dispensers or sharps containers. It includes 1 universal rail clamp (TW705.) for attachment. The clamp has a push-button locking mechanism for easy attachment and removal.

Notes

Order accessory rail (TW700.) separately. Screws must be customer supplied.

Dimensions

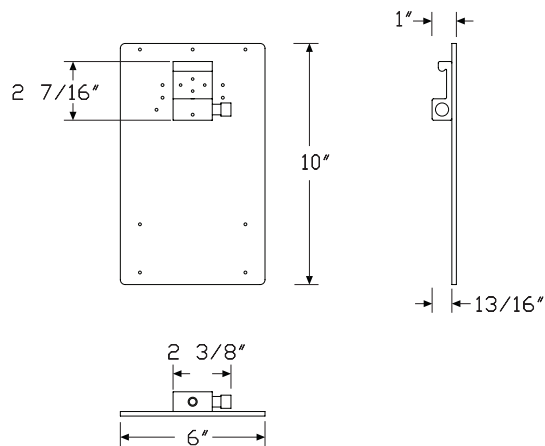

Specification Information

Step 1.

TW706.

\$555

Paper Towel Dispenser Mounting Bracket

TW707.

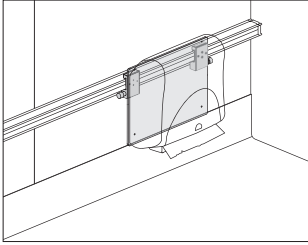

Product Information

Description

This aluminum mounting bracket is designed for use with customer supplied paper towel dispensers. It includes 2 universal rail clamps (TW705.) for attachment. The clamps have a push-button locking mechanism for easy attachment and removal.

Notes

Order accessory rail (TW700.) separately. Screws and dispensers must be customer supplied.

Wide paper towel dispenser dimensions are approximately 10" wide x 5" deep x 8" high. Tall dispenser dimensions are approximately 13" wide x 9" deep x 13" high.

See Compass™ planning guide for additional specification information.

Dimensions

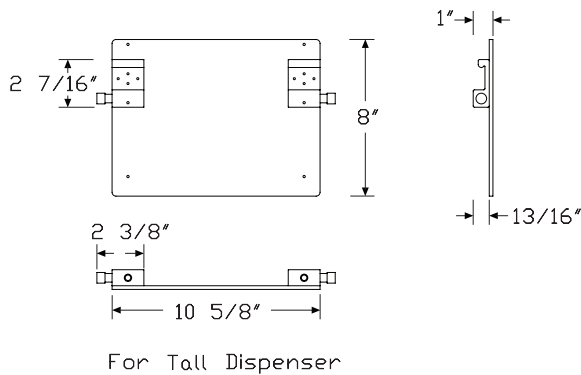
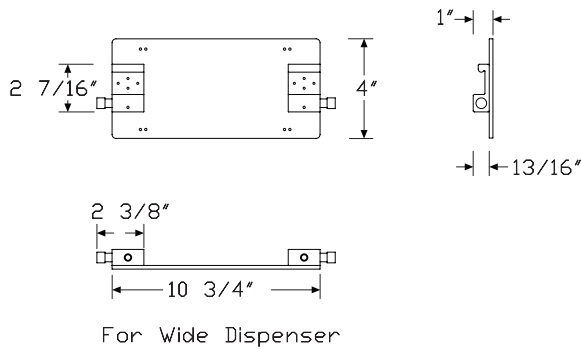

Specification Information

Step 1.

TW707.

Step 2. Size

- A used with wide paper towel dispensers
- B used with tall paper towel dispensers

Prices for Steps 1-2.

TW707. A	\$624
B	\$624

Utility Basket

TW720.

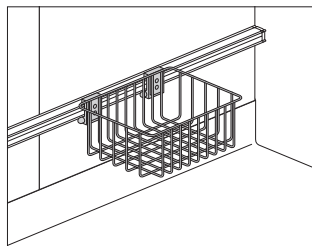

Product Information

Description

This powder-coated wire basket attaches to an accessory rail to hold small items. It includes 2 rail clamps for attachment. The clamps have a push button mechanism that locks the clamp in place and allows for easy attachment and removal. Finish is off-white.

Notes

Order accessory rail (TW700.) separately.

Dimensions

Specification Information

Step 1.

TW720.

Step 2. Size

01 4" high x 8" deep x 10" wide

02 7" high x 8" deep x 10" wide

Prices for Steps 1-2.

TW720. 01 \$572

02 \$593

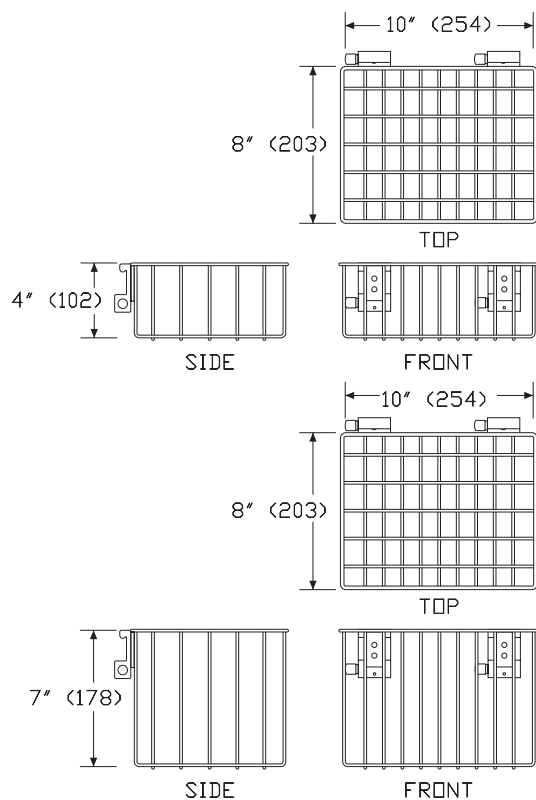

Sharps Container Holder

TW722.

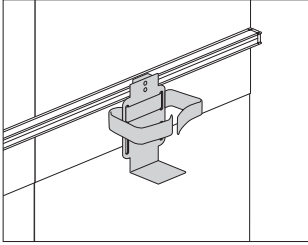

Product Information

Description

This painted holder attaches to an accessory rail and has a strap for holding a variety of customer-supplied sharps containers. It includes a rail clamp for attachment. The clamp has a push button mechanism that locks the clamp in place and allows for easy attachment and removal. Finish is off-white.

Notes

Order accessory rail (TW700.) separately.

Dimensions

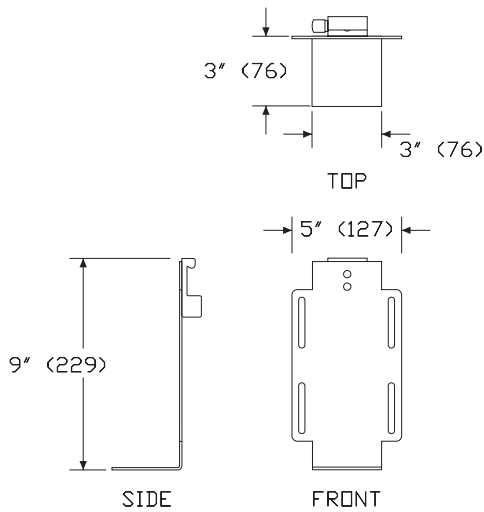

Specification Information

Step 1.

TW722.

\$422

Glove Box Holder

TW724.

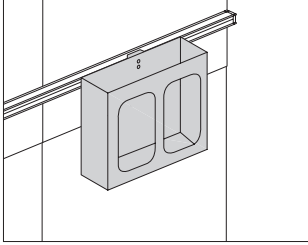

Product Information

Description

This holder attaches to an accessory rail and holds 2 10" x 5" x 3" boxes of gloves. It includes a rail clamp for attachment. The clamp has a push button mechanism that locks the clamp in place and allows for easy attachment and removal. Finish is white.

Notes

Order accessory rail (TW700.) separately.

Dimensions

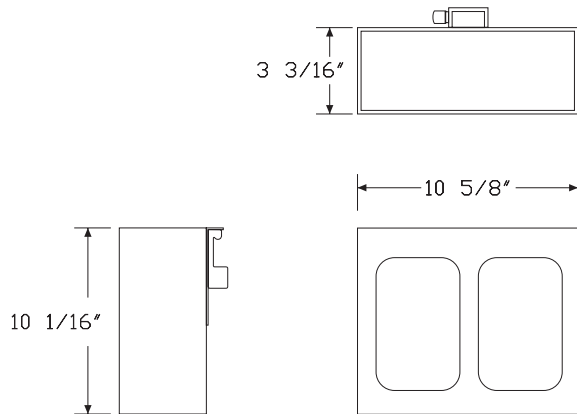

Specification Information

Step 1.

TW724.

\$708

3 Clip Organizer

TW725.

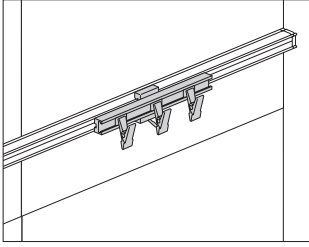

Product Information

Description
This aluminum organizer attaches to an accessory rail and has 3 stainless steel clips for holding IV bags, catheters, and other items. It includes a rail clamp for attachment.

Notes
Order accessory rail (TW700.) separately.

Dimensions

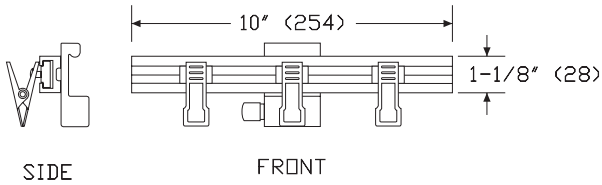

Specification Information

Step 1.
TW725. \$448

Instrument Mounting Bracket

TW726.

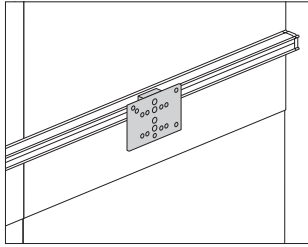

Product Information

Description

This aluminum bracket attaches to an accessory rail to hold a customer-supplied sphygmomanometer, ophthalmoscope with holder, or thermometer with holder. It is designed for products that adhere to the Fairfield standards. The bracket includes a rail clamp for attachment. The clamp has a push button mechanism that locks the clamp in place and allows for easy attachment and removal.

Notes

Order accessory rail (TW700.) separately.

Dimensions

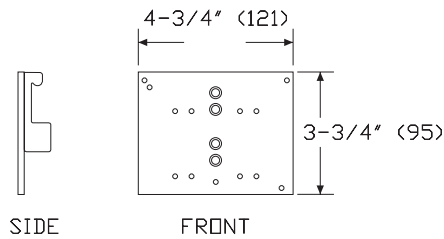

Specification Information

Step 1.

TW726.

\$440

Sphygmomanometer Basket

TW727.

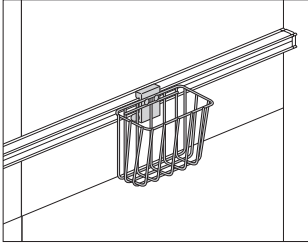

Product Information

Description

This stainless steel wire basket attaches to an accessory rail to hold a customer-supplied blood pressure arm cuff or other small items. It includes a rail clamp for attachment. The clamp has a push button mechanism that locks the clamp in place and allows for easy attachment and removal.

Notes

Order accessory rail (TW700.) separately.

Dimensions

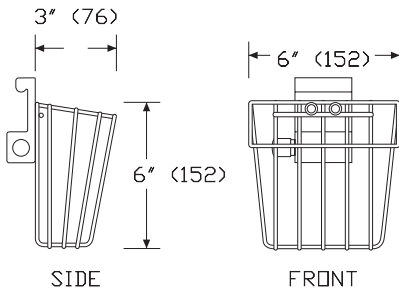

Specification Information

Step 1.

TW727.

\$370

Mounting Clamp

TW740.

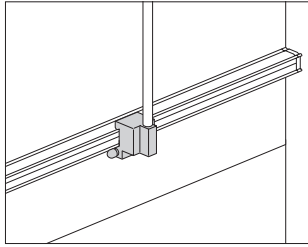

Product Information

Description

This aluminum clamp attaches to an accessory rail to hold components with a post-mount attachment method. It has a push button mechanism that locks the clamp in place and allows for easy attachment and removal.

Notes

Order the following products separately:

- Accessory rail (TW700.)
- Chart holder (TW746.)
- Utility Hook (TW747.)

Dimensions

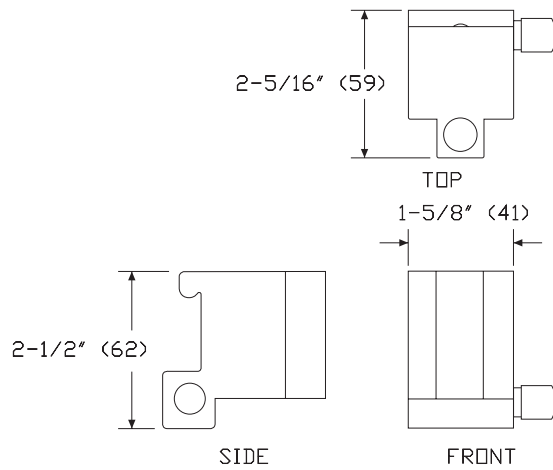

Specification Information

Step 1.

TW740.

\$220

Chart Holder

TW746.

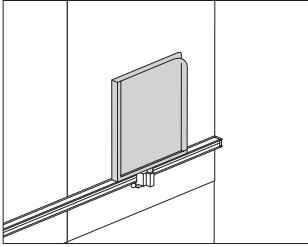

Product Information

Description

This powder-coated holder has a clear acrylic front and holds a chart or other paper items. It has a post for attaching to a mounting clamp. Finish is off-white.

Notes

Order accessory rail (TW700.) and mounting clamp (TW740.) separately.

Dimensions

Specification Information

Step 1.

TW746. \$506

Compass™ Rails and Accessories

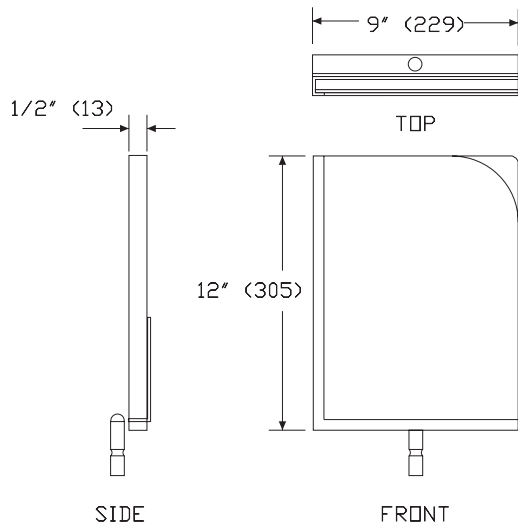

Utility Hook

TW747.

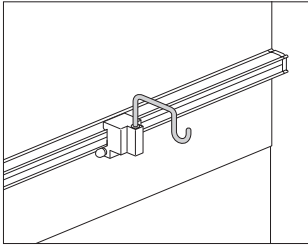

Product Information

Description

This stainless steel hook holds tubing, charts, catheters, or other equipment. It has a post for attaching to a mounting clamp.

Notes

Order accessory rail (TW700.) and mounting clamp (TW740.) separately.

Dimensions

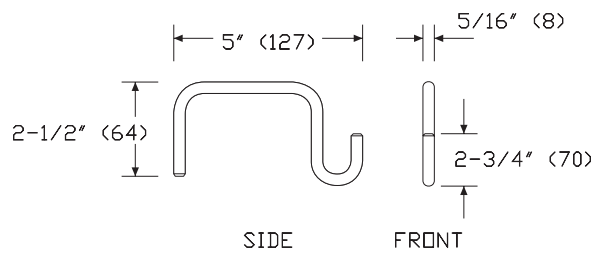

Specification Information

Step 1.

TW747.

\$135

Marker Board

TW800.

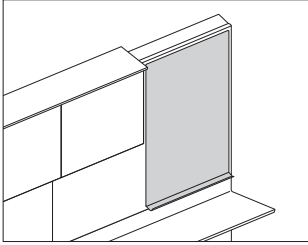

Product Information

Description

This marker board attaches with screws to the front of a face tile to provide an erasable writing surface using dry-erase markers. It has a tray at the bottom for holding markers and erasers. Finish is white.

Dimensions

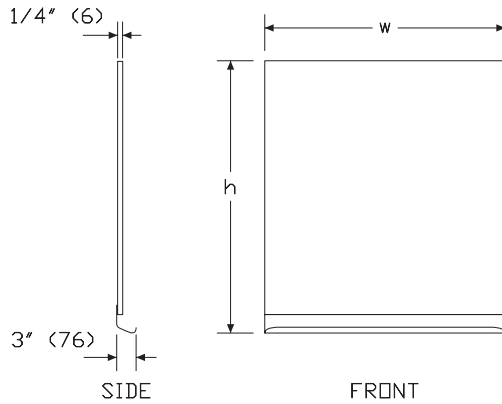

Compass™ Rails and Accessories

Specification Information

Step 1.

TW800.

Step 2. Height

- 20 20" high
- 40 40" high

Step 3. Width

- 24 24" wide
- 36 36" wide

Prices for Steps 1-3.

		24	36
TW800. 20		\$421	499
	40	\$697	887

Display Shelf

TW810.

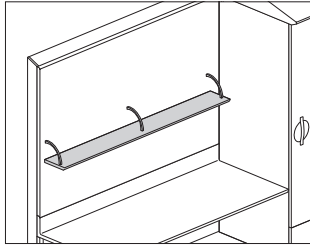

Product Information

Description

This shelf attaches to the front of a face tile to provide small item storage and display. It is available in 3D laminate or Corian® with metallic silver supports. Durawrap™ 3D laminate is a 99.9% PVC-free material. Attachment hardware included.

Dimensions

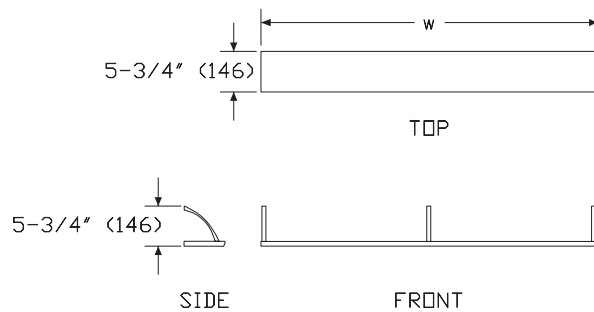

Specification Information

Step 1.

TW810.06

Step 2. Width

18	18" wide
24	24" wide
36	36" wide
48	48" wide

Step 3. Surface Material

A	durawrap™ 3D laminate
K	corian
P	3D laminate <input type="checkbox"/> A

Prices for Steps 1-3.

		A	K	P
TW810.06	18	\$243	586	238
	24	\$268	615	249
	36	\$346	766	318
	48	\$378	952	346

Step 4. Surface Finish

Solid-Color

For durawrap™ 3D laminate (A)

91	white (CP)			+\$0
LU	soft white			+\$0

Wood-Grain

For durawrap™ 3D laminate (A)

LBA	clear on ash (CP)			+\$10
LBB	oak on ash (CP)			+\$10
LBC	walnut on ash (CP)			+\$10
LBU	medium matte walnut (CP)			+\$10

Display Shelf *continued*

Compass™ Rails and Accessories

For corian (K)

58	cameo white	+\$0
CQ	glacier white	+\$0
QB	bisque	+\$0
1S	savannah	+\$130
1U	sahara	+\$130
4I	sandstone	+\$130
ANC	antarctica	+\$130
IQ	aurora	+\$130
OQ	silt	+\$130
SVG	silver gray	+\$130
CRT	concrete	+\$150
DVC	dove	+\$150

For 3D laminate (P)

120	light maple woodgrain 3D laminate <input type="checkbox"/> A	+\$0
121	golden maple woodgrain 3D laminate <input type="checkbox"/> A	+\$0
122	brown walnut woodgrain 3D laminate <input type="checkbox"/> A	+\$0
125	light teak woodgrain 3D laminate <input type="checkbox"/> A	+\$10
126	basic white 3D laminate <input type="checkbox"/> A	+\$0

Index by Product Name

Compass™ System	
	page(s)
1" Conduit Electrical Junction Box	36
3 Clip Organizer	100
Above-Sink Tile	20
Above-Sink Tile, ADA-Compliant Sink	22
Accessory Rail	93
Bed Tile	16
Cantilever	41
Chart Holder	104
Chase	37
Chase Tile	38
Close-out, Bottom	85
Close-out, Side	83
Close-out, Sloped Cabinet Top	86
Close-out, Top	84
Display Shelf	107
Drawer and Printer Module	69
Drawer Liner	80
Drawer Module	64
Electrical 4x4 Junction Box Attachment Bracket	34
Electrical Junction Box Attachment Bracket	33
Face Tile	14
Faucet	53
Full Height Storage Cabinet	59
Glove and Paper Combo Cabinet	78
Glove Box Holder	99
Glove Cabinet	74
Grommet, Close-out	88
Half-Height Storage Cabinet	62
Instrument Mounting Bracket	101
Linen Cart	91
Linen Cart Tile	24
Lower Storage Cabinet with Doors	66
Marker Board	106
Mounting Clamp	103
Nurse Call Trim Plate	31
Paper Towel Cabinet	76
Paper Towel Dispenser Mounting Bracket	96
Rotating Work Surface Arm	43
Rotating Work Surface Support Bracket	42
Rotating Work Surface Tile	19
Rotating Work Surface Top	44
Sharps Container Holder	98
Sidesplash	55
Sidesplash, ADA Compliant	56
Sink, 13" Deep	46
Sink, 21" Deep	47

Sink, ADA Compliant	48
Sink, Basic 13" Deep	54
Sink Enclosure	49
Sink Enclosure, ADA-Compliant Sink	51
Soap and Sanitizer Mounting Bracket	95
Sphygmomanometer Basket	102
Stile, Chase Tile	13
Stile Connector Kit	12
Stile Lockdown	11
Stile, Rail-Attached	9
Storage Cabinet	72
Supply Cart	89
TV/Monitor Support Bracket	35
Universal Rail Clamp	94
Utility Basket	97
Utility Hook	105
Utility Support Rail	32
Utility Tile, Electrical, Full-Height Upper	29
Utility Tile, Electrical, Lower	25
Utility Tile, Electrical, Partial-Height Upper	27
Wall Anchors	8
Wall Rail	5
Wall Rail End Cap	7
Wall Rail Insert	6
Wardrobe Cabinet	57
Waste Receptacle Cabinet	81
Work Surface	39
Work Surface Tile	17

Index: Product Name

Index by Product Number

TW100. Wall Rail	page(s) 5	TW316. Waste Receptacle Cabinet	81
TW102. Wall Rail Insert	6	TW320. Storage Cabinet	72
TW104. Wall Rail End Cap	7	TW322. Glove Cabinet	74
TW109. Wall Anchors	8	TW324. Paper Towel Cabinet	76
TW110. Stile, Rail-Attached	9	TW326. Glove and Paper Combo Cabinet	78
TW112. Stile Lockdown	11	TW390. Drawer Liner	80
TW113. Stile Connector Kit	12	TW400. Close-out, Side	83
TW114. Stile, Chase Tile	13	TW402. Close-out, Top	84
TW120. Face Tile	14	TW404. Close-out, Bottom	85
TW122. Bed Tile	16	TW406. Close-out, Sloped Cabinet Top	86
TW124. Work Surface Tile	17	TW409. Grommet, Close-out	88
TW126. Rotating Work Surface Tile	19	TW501. Linen Cart	91
TW128. Above-Sink Tile	20	TW503. Supply Cart	89
TW129. Above-Sink Tile, ADA-Compliant Sink	22	TW700. Accessory Rail	93
TW130. Linen Cart Tile	24	TW705. Universal Rail Clamp	94
TW140. Utility Tile, Electrical, Lower	25	TW706. Soap and Sanitizer Mounting Bracket	95
TW141. Utility Tile, Electrical, Partial-Height Upper	27	TW707. Paper Towel Dispenser Mounting Bracket	96
TW142. Utility Tile, Electrical, Full-Height Upper	29	TW720. Utility Basket	97
TW159. Nurse Call Trim Plate	31	TW722. Sharps Container Holder	98
TW170. Utility Support Rail	32	TW724. Glove Box Holder	99
TW172. Electrical Junction Box Attachment Bracket	33	TW725. 3 Clip Organizer	100
TW174. Electrical 4x4 Junction Box Attachment Bracket	34	TW726. Instrument Mounting Bracket	101
TW175. TV/Monitor Support Bracket	35	TW727. Sphygmomanometer Basket	102
TW176. 1" Conduit Electrical Junction Box	36	TW740. Mounting Clamp	103
TW180. Chase	37	TW746. Chart Holder	104
TW182. Chase Tile	38	TW747. Utility Hook	105
TW210. Work Surface	39	TW800. Marker Board	106
TW211.		TW810. Display Shelf	107
TW219. Cantilever	41		
TW221. Rotating Work Surface Arm	43		
TW222. Rotating Work Surface Top	44		
TW229. Rotating Work Surface Support Bracket	42		
TW230. Sink, 13" Deep	46		
TW231. Sink, 21" Deep	47		
TW232. Sink Enclosure	49		
TW233. Sink Enclosure, ADA-Compliant Sink	51		
TW234. Sink, Basic 13" Deep	54		
TW235. Sink, ADA Compliant	48		
TW239. Faucet	53		
TW242. Sidesplash	55		
TW243. Sidesplash, ADA Compliant	56		
TW300. Wardrobe Cabinet	57		
TW302. Full Height Storage Cabinet	59		
TW305. Half-Height Storage Cabinet	62		
TW310. Drawer Module	64		
TW312. Lower Storage Cabinet with Doors	66		
TW314. Drawer and Printer Module	69		





20-Day or Less/Assigned Lead-Time Order Information — Healthcare

GSA

20-Day or Less/Assigned Lead-Time Programs

20-day or less and assigned lead-time products are designed for established Herman Miller dealers with pre-approved credit.

Products are distributed from multiple manufacturing facilities across the United States. All products and options not designated by an Assigned Lead-Time icon  will ship in 20 business days or less after being acknowledged by Herman Miller. Products and options designated by an  are on the assigned lead-time program and will ship in 20 days, less than 20 days, or more than 20 days from order acknowledgement.

Ordering Procedure

Please place orders through Order Manager. If this is not available to you, place orders through mail or fax. Verbal purchase orders will not be accepted.

Order Entry fax number: (616) 654 3085.

For more information, contact your Customer Care representative at: (866) 854 3048 ext 3400

Shipments and Delivery

Per Herman Miller Terms and Conditions.

Changes and Cancellation

Per Herman Miller Terms and Conditions.



Packaging/Keyed-Alike Information — Compass™ System

GSA

Packaging

Packaging varies according to individual product. A surcharge may be added for special packaging requests. Contact Customer Care for specific information.

Keyed-Alike Locks

All components with locks may be specified keyed alike.

Keyed-alike Compass System components will be shipped with lock chassis installed. Lock plugs will be shipped separately, tagged for product and location as specified. Installation of lock plugs will be on-site according to instructions provided. Herman Miller Inc., will not be responsible for lock plug installation.

To order keyed-alike locks for Compass System components, specify keyed alike. Then place a separate order for plugs and locks:

1. List plug part number and key number (232092-XXX); select a key number (or numbers) between 226 and 427, excluding numbers 408 and 412.
2. List quantity of locks per key number.
3. Indicate this is a no charge order.

Keyed-alike locks are field installed.

A master key can be used to open any lock on a Compass System component. To remove lock plugs from existing components, a removal key (#232228) or lock change tool (#234559) is required. Customers interested in ordering master keys, removal keys, or lock change tools should contact Customer Care with a written request.

For more information about our products and services or to see a list of dealers, please visit us at HermanMiller.com or call (800) 851 1196.

© 2025 Herman Miller, Inc., Zeeland, Michigan

Distribution Rights

Working together since 1956, Herman Miller and Vitra are the authentic sources of designs by Charles and Ray Eames, Alexander Girard, and George Nelson. All the designs shown in this book are protected by law. Herman Miller has obtained all rights to make and sell these designs. Also, Herman Miller holds exclusive worldwide manufacturing and distribution rights for these products with the following exceptions:

Charles and Ray Eames, George Nelson, and Alexander Girard—Worldwide distribution rights for furniture in all areas except Europe and the Middle East. For those areas, please contact Vitra.

Isamu Noguchi—Worldwide distribution rights for the Noguchi Rudder Table. Distribution rights for the Noguchi Table in North America and Central America only. For all other areas, please contact Vitra.

Magis—Exclusive distribution rights in the US and Canada. For all other areas, please contact Magis.

® HermanMiller, , Action Office, Aeron, Aside, Canvas Office Landscape, Caper, Cosm, Co/Struc, Eames, Embody, Ethospace, Exclave, Fine-Tune, FlexFront, Formcoat, Ground Cloth, Intent, Layout Studio, Lino, Maharam, Meridian, Mirra, Motia, Nelson, Pellicle, Perspectives, Plex, PostureFit, PostureFit SL, Sayl, Setu, Tu, Verus, Y-Tower and Zeph are among the registered trademarks of Herman Miller, Inc., and its owned subsidiaries.

™ AireWeave, Bubbletack, Canvas Vista, Cellular Suspension, Commend, Compass, Connect, DOT, Durawrap, Everywhere, Flex-Edge, Headway, Hopsak 2, Iota, Keyless Entry, Latitude, Lyris 2, Mora, Multiscrim, Nevi, OE1, OE1 Workspace Collection, Overlay, Renew, Stackable, Swoop, Thrive, TriFlex, Twist and Valor are among the trademarks of Herman Miller, Inc., and its owned subsidiaries.

Chemsurf® is a registered trademark of Wilsonart International.

Corian® is a registered trademark of E.I. du Pont de Nemours and Company Corporation.

FLEXNET™ is a trademark of Milliken & Company.

Floor Saver Glide® is a registered trademark of Carpin Manufacturing, Inc.

Forest Stewardship Council® is a registered trademark of the Forest Stewardship Council A.C. (FSC). We are FSC® certified (FSC® C102895).

FSC® is a registered trademark of the Forest Stewardship Council A.C. (FSC).

MicrobeCare™ is a trademark of Parasol Medical LLC.

Microsoft® and Natural® Keyboard are registered trademarks of Microsoft Corporation.

Place Textiles® is a registered trademark of Place Textiles.